

# FISH SCALE SHINGLE INSTALLATION DETAILS

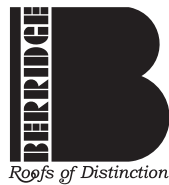
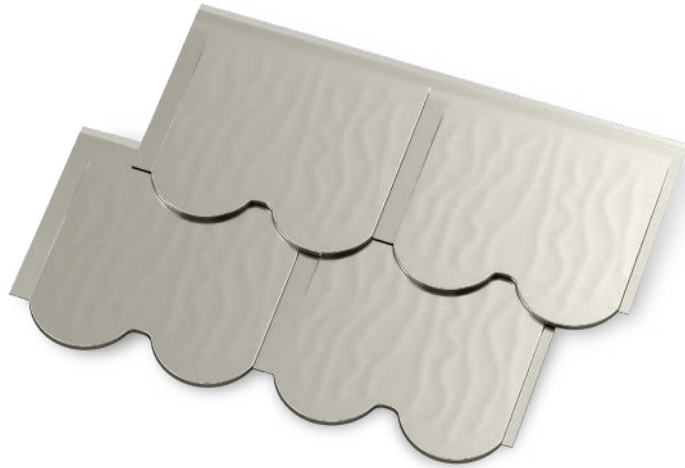

**BERRIDGE  
MANUFACTURING  
COMPANY**

**800-669-0009 • [www.Berridge.com](http://www.Berridge.com)**

INDEX	FSS-0
INSTALLATION INSTRUCTIONS	FSSI-1
INSTALLATION INSTRUCTIONS	FSSI-2
INTRODUCTION TO TYPICAL DETAILS	FSSI-3
SHINGLE OVERVIEW	FSS-1
FASCIA DETAIL; BELOW EAVE	FSS-10
FASCIA DETAIL; BELOW GABLE	FSS-11
FASCIA SILL	FSS-20
FASCIA OUTSIDE CORNER	FSS-21
FASCIA END WALL	FSS-22
FASCIA PARAPET	FSS-23
FASCIA/SOFFIT DETAIL;	FSS-30
FASCIA/SOFFIT DETAIL;	FSS-31
WALL/SOFFIT DETAIL;	FSS-32
SILL AT SLAB DETAIL;	FSS-40
SILL AT SLAB DETAIL;	FSS-41
SILL AT BRICK DETAIL;	FSS-42
SILL AT VERTICAL PANEL DETAIL;	FSS-43
HEADER DETAIL;	FSS-50
WINDOW/DOOR JAMB;	FSS-51
JAMB DETAIL;	FSS-52
SILL DETAIL;	FSS-53
INSIDE CORNER DETAIL;	FSS-60
OUTSIDE CORNER DETAIL;	FSS-61
PARAPET DETAIL;	FSS-70
HEAD WALL DETAIL;	FSS-71
RAKE WALL DETAIL;	FSS-72



**Berridge  
Manufacturing  
Company**

## INDEX

**FISH SCALE SHINGLE**

DATE: 03/22/08

PAGE\FILE

**FSS-0**

1. BERRIDGE FISH SCALE SHINGLE: HAS AN EXPOSURE OF NOMINAL 11-1/2" X 8 1/2" AND HAS A DEPTH OF 5/16" AT BOTTOM OF SHINGLE AND FLUSH AT THE TOP.

THE SHINGLE IS FACTORY FABRICATED. WITH 148 SHINGLES PER SQUARE.

GENERAL NOTES

1. SHINGLES MAY BE USED FOR GABLE, SIDEWALL, FASCIA OR MANSARD WITH 80 DEGREE + SLOPE.

2. SHINGLES TO BE INSTALLED OVER SOLID SHEATHING.

A. MATERIAL STORAGE: CAUTION MUST BE EXERCISED IN THE STORAGE OF MATERIALS PRIOR TO INSTALLATION. KEEP ALL BERRIDGE PRE FINISHED MATERIAL IN A DRY LOCATION WITH ADEQUATE VENTILATION AND OUT OF DIRECT SUNLIGHT.

EXPOSURE TO DIRECT SUNLIGHT AND/OR MOISTURE MAY CAUSE THE FACTORY-APPLIED STRIPPABLE PROTECTIVE PLASTIC FILM TO ADHERE TO THE METAL PERMANENTLY AND CAUSE DISCOLORATION OF THE FINISH.

B. STRIPPABLE PROTECTIVE FILM: THE STRIPPABLE PLASTIC FILM WHICH IS APPLIED OVER MOST BERRIDGE PRE FINISHED PRODUCTS, PANELS, FLASHINGS, COILS AND SHEETS PROVIDES PROTECTION OF THE FINISH DURING FABRICATION AND TRANSIT. THIS FILM MUST BE REMOVED PRIOR TO INSTALLATION.

C. SHEATHING: SOLID SHEATHING IS TO BE EITHER BERRIDGE 24 GA "S-DECK" CORRUGATED METAL DECKING OR A MINIMUM OF 1/2" SOLID WOOD SHEATHING TO PROVIDE SUFFICIENT HOLDING STRENGTH FOR FASTENERS. SHEATHING TO BE IN PLANE ± 1/4" IN 20'.

D. FELT UNDERLAYMENT: USE NUMBER THIRTY (# 30) FELT PAPER (OR EQUAL) BENEATH SHINGLES. INSTALL FELT PARALLEL TO BASE OF PANELS, STARTING AT THE BOTTOM AND USING MINIMUM 6" LAPS. USE ONLY BERRIDGE COATED FELT CAPS TO PREVENT RUST. USE ONLY GALVANIZED OR COATED FASTENERS.

MINIMUM # 30 FELT UNDERLAYMENT AT STRAIGHT WALL APPLICATIONS; GRACE ICE & WATERSHIELD UNDERLAYMENT (OR EQUAL) AT MANSARD APPLICATIONS (MANSARDS 80 DEGREE + SLOPE

DO NOT USE RED ROSIN PAPER WITH ANY BERRIDGE MANUFACTURING PRODUCT.

E. SEALANT RECOMMENDATIONS: TREMCO SPECTRUM ONE SILICONE SEALANT. DO NOT USE CLEAR CAULK.

F. ELECTROLYSIS: AVOID ALLOWING FLASHINGS AND SHINGLES TO COME INTO CONTACT WITH EITHER LEAD OR COPPER, AND PREVENT EXPOSURE TO WATER RUN OFF FROM LEAD AND/OR COPPER.

G. STRUCTURAL FRAMING: PRIOR TO SHINGLE INSTALLATION, INSPECT SIDEWALL, FASCIA OR OTHER FRAMING TO DETERMINE:

1. FRAMING MUST BE SQUARE AND PLUMB.

2. INSURE THAT SIDEWALL COLUMNS AND GIRTS ARE IN THE SAME PLANE, PLUS OR MINUS 1/4" IN 20'.

H. FLASHING: IF BERRIDGE MANUFACTURING COMPANY IS TO SUPPLY FLASHINGS, THEY WILL BE FABRICATED IN 10'-0" LENGTHS WITH SQUARE END CUTS ONLY. THE PURCHASER MUST PROVIDE ALL DIMENSION AND DEGREE OF ANGLES.



**Berridge  
Manufacturing  
Company**

# INSTALLATION INSTRUCTIONS

## FISH SCALE SHINGLE

DATE: 03/22/08

PAGE\FILE

FSSI-I

- I. FLASHING INSTALLATION: FIRST, REMOVE STRIPPABLE PLASTIC FILM FROM ALL FLASHINGS, THEN INSTALL ACCORDING TO BERRIDGE TYPICAL INSTALLATION DETAILS. ALWAYS STAGGER FLASHING JOINTS WHEN ONE FLASHING IS INSTALLED OVER OTHER FLASHINGS.
- J. SHINGLE INSTALLATION:
1. REMOVE STRIPPABLE PLASTIC FILM FROM EACH SHINGLE PRIOR TO INSTALLATION.
  2. START SHINGLE INSTALLATION FROM BOTTOM OF WALL OR SILL AND WORK UP TO TOP OF WALL.
  3. KEEP EACH SHINGLE TIGHT AGAINST THE ADJOINING SHINGLE.
  4. SHINGLE SIDE JOINTS SHALL BE PERPENDICULAR TO SILL.
- K. FASTENERS: INSTALL FASTENERS AS PER TYPICAL DETAILS. USE 11 GAUGE 1-1/4" GALVANIZED ROOFING NAILS FOR INSTALLATION OVER WOOD SHEATHING AND USE #10 PANCAKE HEAD TEKS FASTENERS (ZINC-PLATED SCREW WITH PHILLIPS INSERT, AS MADE BY CONSTRUCTION FASTENERS CO.) FOR INSTALLATION TO METAL. WHEN USING POP RIVETS ON FLASHING, STAINLESS STEEL RIVETS ARE RECOMMENDED TO AVOID RUST STAINS.\*

MAKE SURE ALL FASTENERS ARE DRIVEN STRAIGHT AND SET FLAT. DO NOT OVERDRIVE FASTENERS, AS THIS WILL CAUSE THE SHINGLE AND OR FLASHING TO BUCKLE OR BECOME RECESSED BELOW THE ELEVATION OF THE SUBSTRATE.

ALL FASTENERS ARE TO BE GALVANIZED, STAINLESS STEEL OR COATED.

BERRIDGE MANUFACTURING COMPANY STRIVES TO PROVIDE ITS CUSTOMERS WITH THE HIGHEST QUALITY STRETCHER LEVELED STEEL AVAILABLE. THE LATEST TECHNOLOGY IS ALSO INCORPORATED IN BERRIDGE'S HIGH-PRECISION COIL HANDLING AND ROLL FORMING EQUIPMENT TO MINIMIZE THE STRESS ON METAL DURING PRODUCTION. FURTHERMORE, BERRIDGE UTILIZES HEAVIER 24 GAUGE METAL RATHER THAN 26 GAUGE STEEL OR LIGHT GAUGE ALUMINUM AS OFFERED BY MANY COMPETITORS. ALL THESE MEASURES HAVE BEEN TAKEN TO MINIMIZE THE AMOUNT OF "OIL-CANNING" (WAVINESS) WHICH IS NATURALLY INHERENT IN FLAT SHEET METAL. MANY TIMES, HOWEVER, THE CAUSE OF WAVINESS OR "OIL-CANNING" CAN BE TRACED TO UNEVEN SHEATHING, OR IMPROPER FELT INSTALLATION.

ALL ARCHITECTURAL SHINGLES REQUIRE CARE IN HANDLING AND INSTALLATION TO AVOID DAMAGING OR DEFORMING THE SHINGLES.

\*CONSULT BERRIDGE MANUFACTURING'S ENGINEERING DEPARTMENT REGARDING FASTENER SPACING TO MEET DESIGN CRITERIA, AND THE USE OF ANY OTHER TYPE OF FASTENER.

DATE: 03/22/08

## INSTALLATION INSTRUCTIONS

PAGE\FILE

FSSI-2

### FISH SCALE SHINGLE



**Berridge  
Manufacturing  
Company**

*Roofs of Distinction*

THE DETAILS CONTAINED IN THE FOLLOWING PAGES ARE MERELY RECOMMENDATIONS AS TO HOW BERRIDGE MANUFACTURING MATERIALS SHOULD BE INSTALLED. THEY MAY REQUIRE ADAPTATIONS OR MODIFICATIONS FOR A SPECIFIC PROJECT AS CONDITIONS VARY IN BOTH BUILDING DESIGN AND LOCAL WEATHER PECULIARITIES.

BERRIDGE MANUFACTURING COMPANY SHALL BE HELD HARMLESS FROM ANY AND ALL CLAIMS ARISING FROM LACK OF WATERTIGHTNESS AS A RESULT OF FOLLOWING THESE RECOMMENDED DETAILS. ENSURING WATERTIGHTNESS ON ANY GIVEN PROJECT IS THE FUNCTION OF THE INSTALLER. THE ARCHITECT/GENERAL CONTRACTOR/INSTALLER MUST ACCEPT THE RESPONSIBILITY TO ADAPT THESE DETAILS TO MEET PARTICULAR BUILDING REQUIREMENTS AND TO ASSURE ADEQUATE WATERTIGHTNESS.

THE INSTALLER CAN VIRTUALLY ASSURE WATERTIGHTNESS IF THESE FLASHING DETAILS HAVE BEEN PROPERLY ADAPTED, ADEQUATE LAPS HAVE BEEN PROVIDED, CORRECT TYPE OF SEALANT USED, ALL JOINTS ADEQUATELY CAULKED, AND PROFESSIONAL WORKMANSHIP EMPLOYED.

 <p><b>Berridge Manufacturing Company</b></p> <p><i>Roofs of Distinction</i></p>	INTRODUCTION TO TYPICAL DETAILS	DATE: 03/22/08
	FISH SCALE SHINGLE	PAGE\FILE FSSI-3

**BERRIDGE FISH SCALE SHINGLE**

HISTORICAL PRODUCT INSTALLED OVER SOLID SHEATHING; FOR GABLE, SIDEWALL, FASCIA OR MANSARD (80 DEGREE + SLOPE)

EACH SHINGLE IS STAMPED WITH TWO SCALE MODULES PER SHINGLE. THE EXPOSURE TO THE WEATHER SHALL BE 8-1/2" BY 11-1/2" PER SHINGLE.

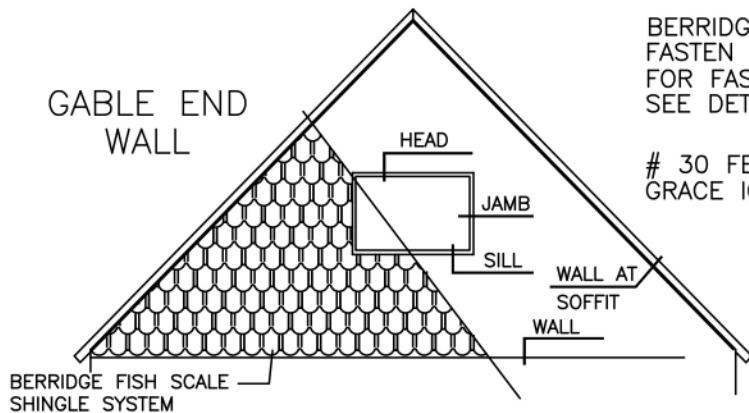

BERRIDGE FISH SCALE SHINGLE FASTEN TO PLYWOOD, FOR FASTENER PATTERN SEE DETAIL BELOW

# 30 FELT UNDERLAYMENT GRACE ICE & WATERSHIELD AT MANSARD

SOLID SHEATHING MINIMUM 1/2" PLYWOOD

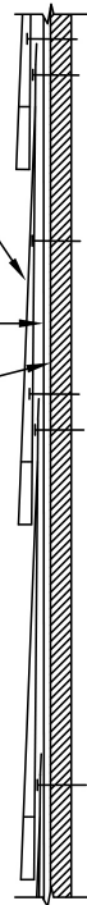

SECTION DETAIL

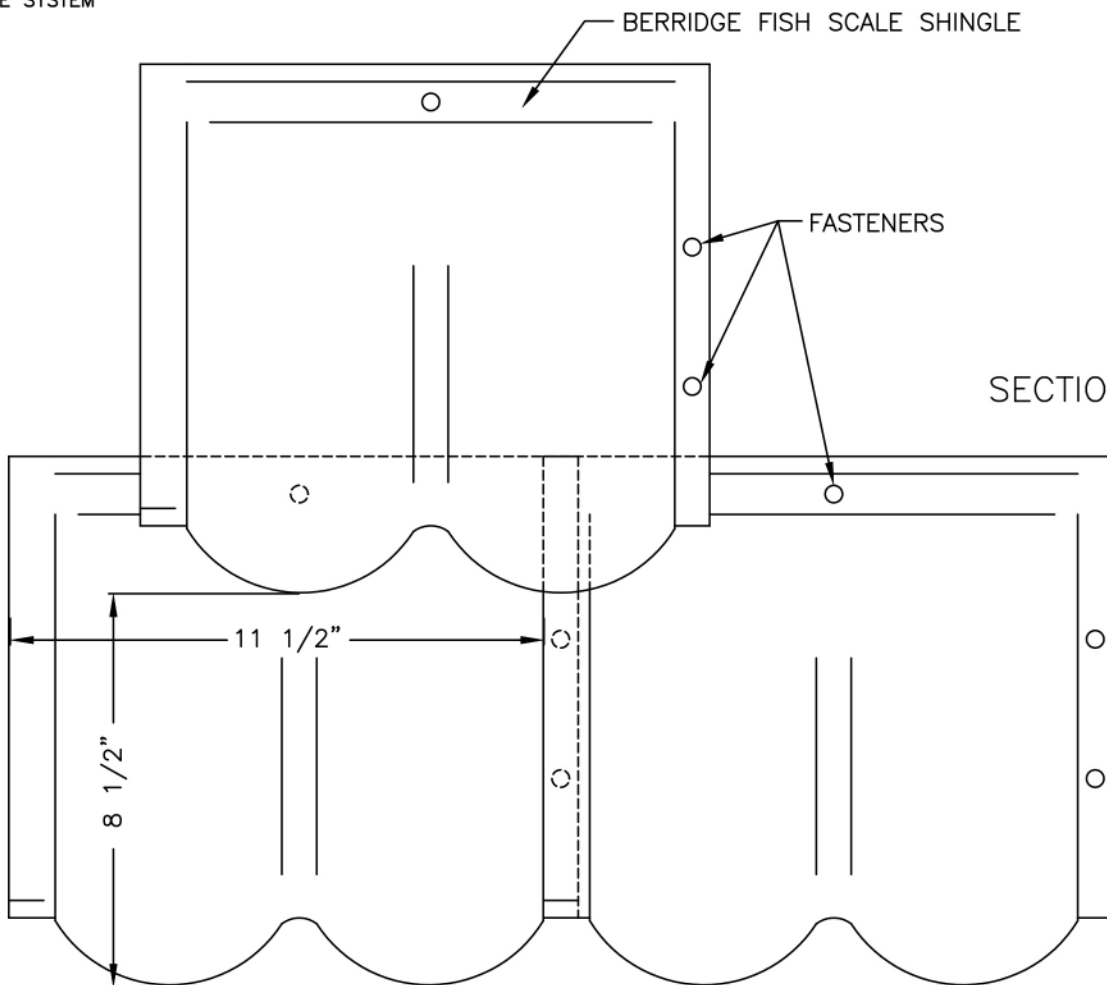

FISH SCALE SHINGLE DETAIL



**Berridge Manufacturing Company**

SHINGLE OVERVIEW

FISH SCALE SHINGLE

DATE: 03/22/08

PAGE\FILE

FSS-I

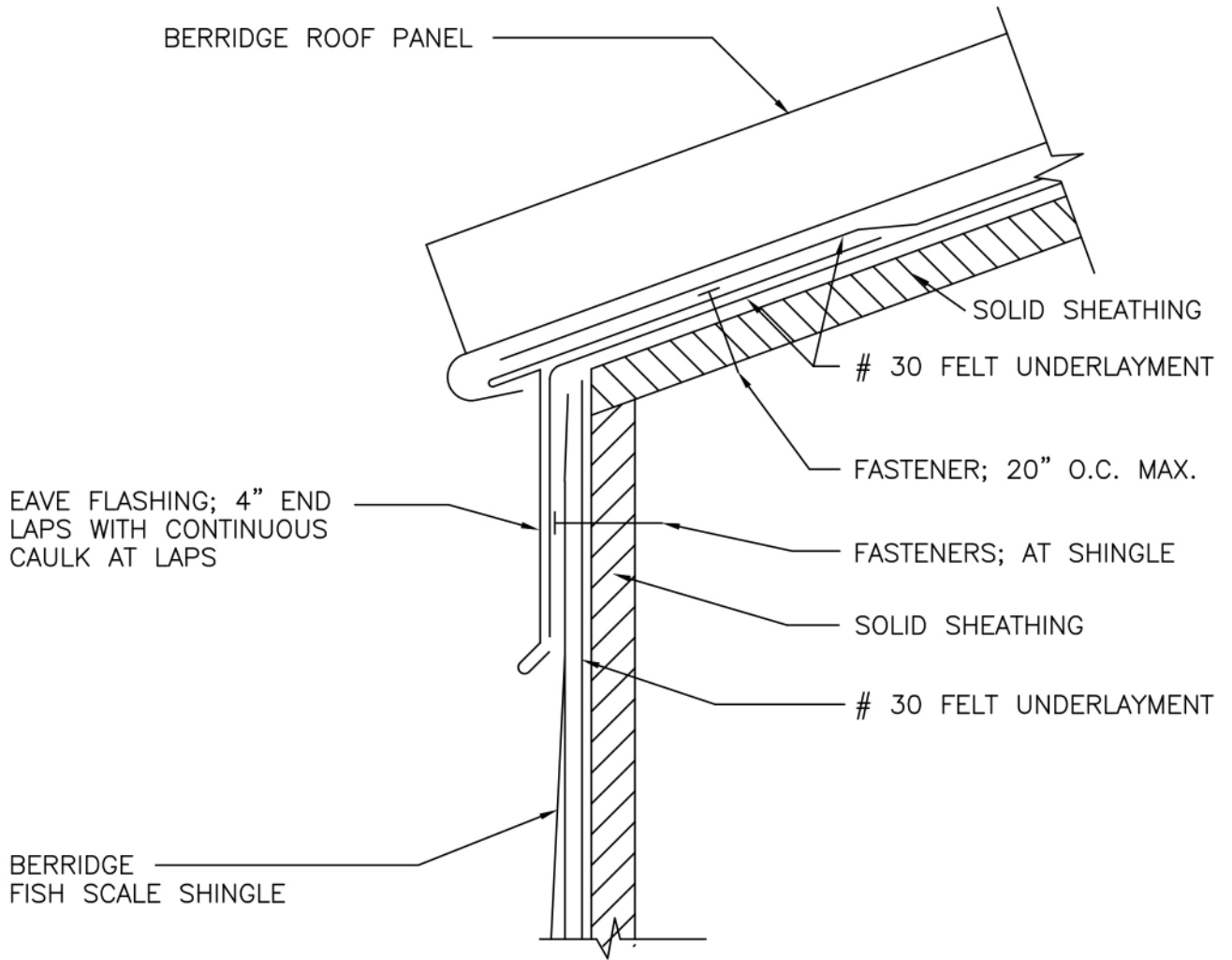

1. SOLID SHEATHING (BY OTHERS) TO BE MINIMUM 1/2" PLYWOOD OR EQUIVALENT IN STRENGTH FOR HOLDING POWER OF FASTENERS.
2. ALL FELT UNDERLAYMENT, CAULKING, AND FASTENERS, ARE ITEMS TO BE FURNISHED AND INSTALLED BY THE ROOFING INSTALLER AT THE DISCRETION OF THE ARCHITECT.

F = FINISH SIDE

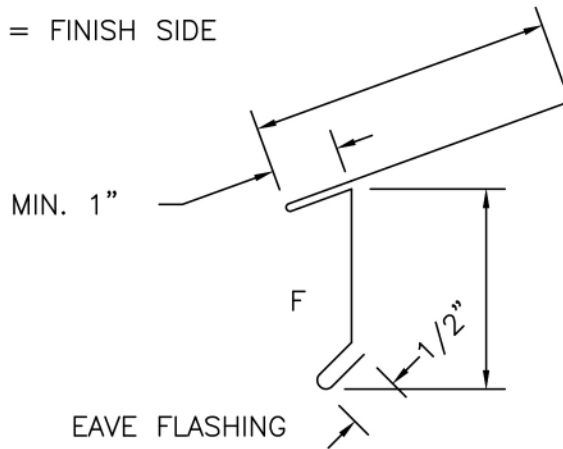

**Berridge**  
**Manufacturing**  
**Company**

FASCIA DETAIL  
 BELOW EAVE

FISH SCALE SHINGLE

DATE: 03/22/08

PAGE\FILE

FSS-10

BERRIDGE ROOF PANEL

DRIP FLASHING; 4" END LAPS WITH CONTINUOUS CAULK AT LAPS

BERRIDGE FISH SCALE SHINGLE

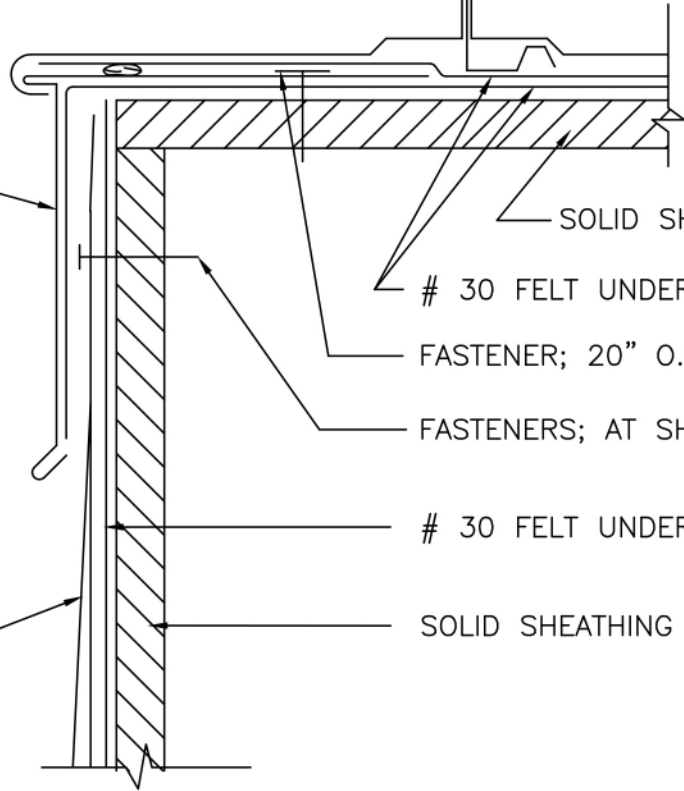

SOLID SHEATHING

# 30 FELT UNDERLAYMENT

FASTENER; 20" O.C. MAX.

FASTENERS; AT SHINGLE

# 30 FELT UNDERLAYMENT

SOLID SHEATHING

1. SOLID SHEATHING (BY OTHERS) TO BE MINIMUM 1/2" PLYWOOD OR EQUIVALENT IN STRENGTH FOR HOLDING POWER OF FASTENERS.

2. ALL FELT UNDERLAYMENT, CAULKING, AND FASTENERS, ARE ITEMS TO BE FURNISHED AND INSTALLED BY THE ROOFING INSTALLER AT THE DISCRETION OF THE ARCHITECT.

F = FINISH SIDE

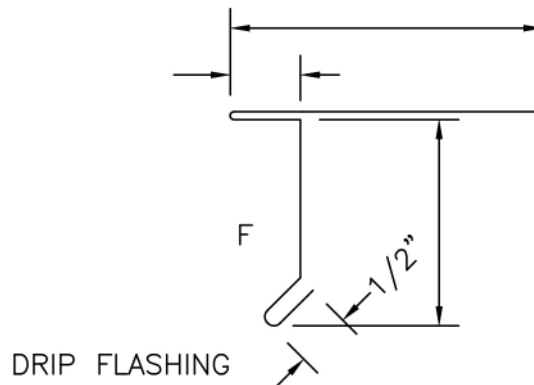

DRIP FLASHING

DATE: 03/22/08

FASCIA DETAIL  
BELOW GABLE

PAGE\FILE  
FSS-II

FISH SCALE SHINGLE



Berridge  
Manufacturing  
Company

Roofs of Distinction



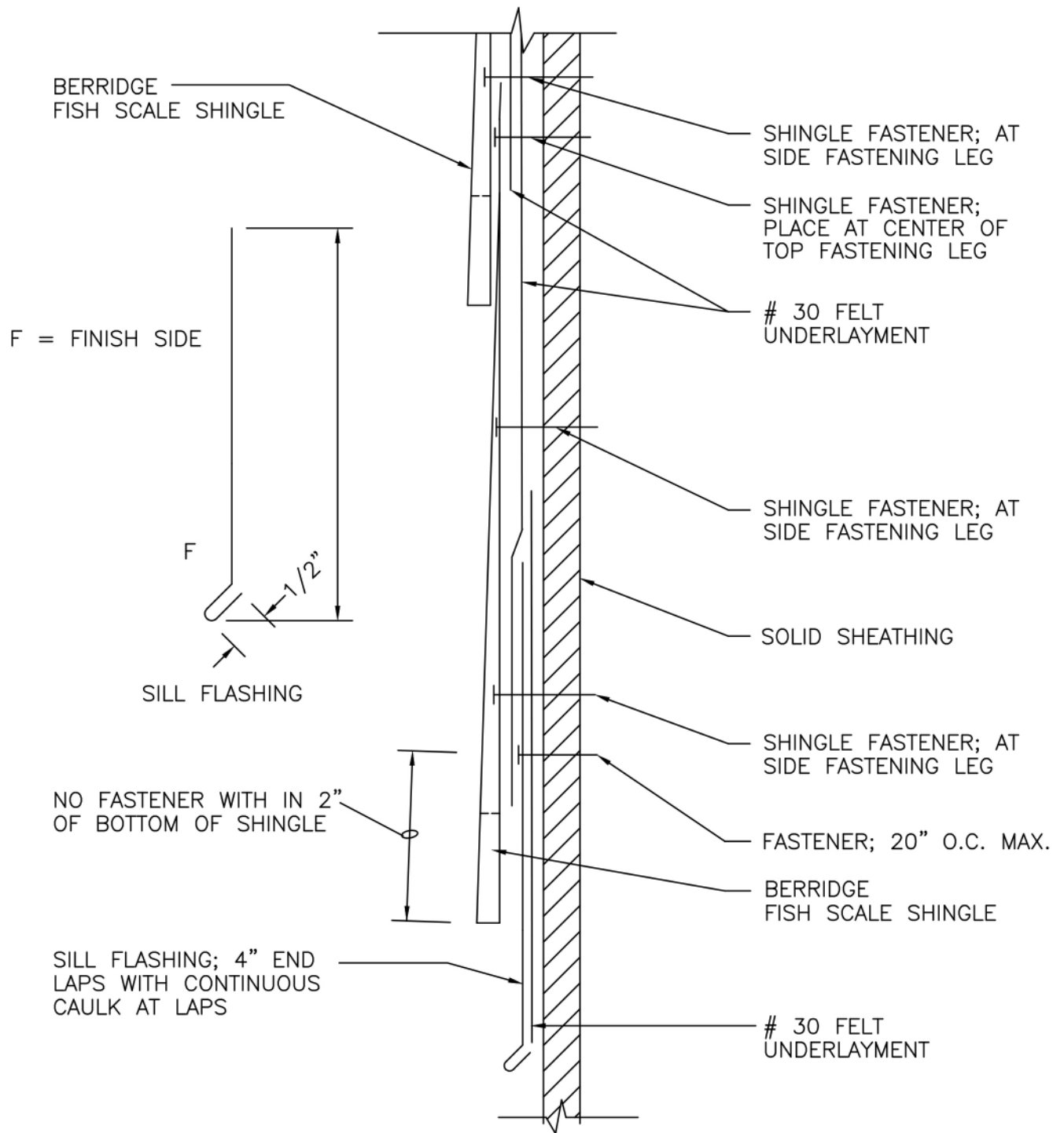

1. SOLID SHEATHING (BY OTHERS) TO BE MINIMUM 1/2" PLYWOOD OR EQUIVALENT IN STRENGTH FOR HOLDING POWER OF FASTENERS.
2. ALL FELT UNDERLAYMENT, CAULKING, AND FASTENERS, ARE ITEMS TO BE FURNISHED AND INSTALLED BY THE ROOFING INSTALLER AT THE DISCRETION OF THE ARCHITECT.



**Berridge  
Manufacturing  
Company**

*Roofs of Distinction*

FASCIA SILL

FISH SCALE SHINGLE

DATE: 03/22/08

PAGE\FILE

FSS-20

CORNER CAP; 4" END LAPS WITH  
CONTINUOUS CAULK AT LAPS.  
POP RIVET TO EVERY SHINGLE  
CAULK RIVET HEADS

CONTINUOUS BEAD OF CAULK

BERRIDGE  
FISH SCALE SHINGLE

BERRIDGE  
FISH SCALE SHINGLE

SHINGLE FASTENER

# 30 FELT  
UNDERLAYMENT

SOLID SHEATHING

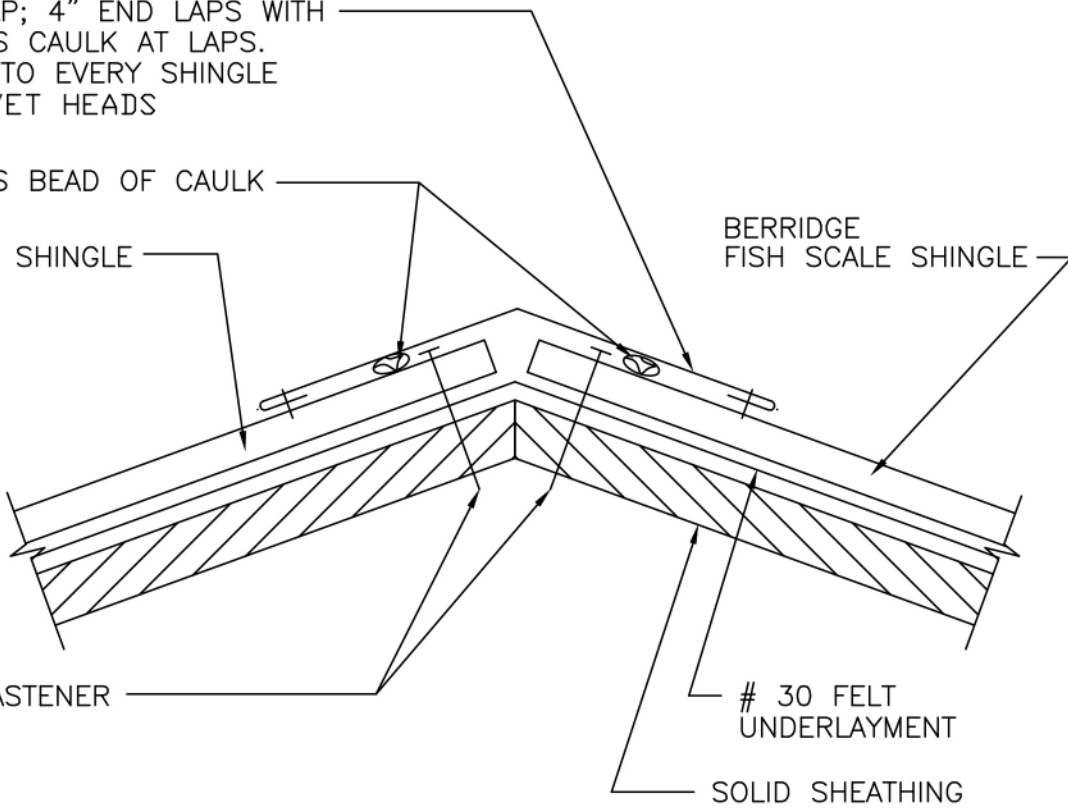

1. SOLID SHEATHING (BY OTHERS) TO BE MINIMUM 1/2" PLYWOOD OR EQUIVALENT IN STRENGTH FOR HOLDING POWER OF FASTENERS.
2. ALL FELT UNDERLAYMENT, CAULKING, AND FASTENERS, ARE ITEMS TO BE FURNISHED AND INSTALLED BY THE ROOFING INSTALLER AT THE DISCRETION OF THE ARCHITECT.

F = FINISH SIDE

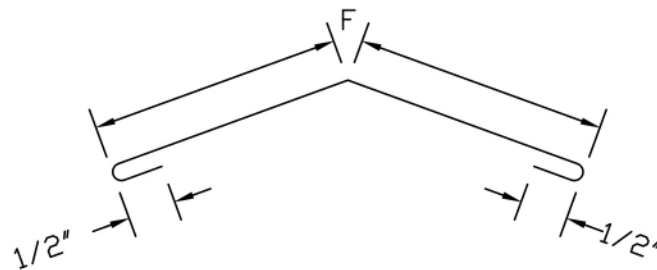

CORNER CAP

DATE: 03/22/08

FASCIA  
OUTSIDE CORNER DETAIL

PAGE\FILE

FSS-2I

FISH SCALE SHINGLE



Berridge  
Manufacturing  
Company

Roofs of Distinction

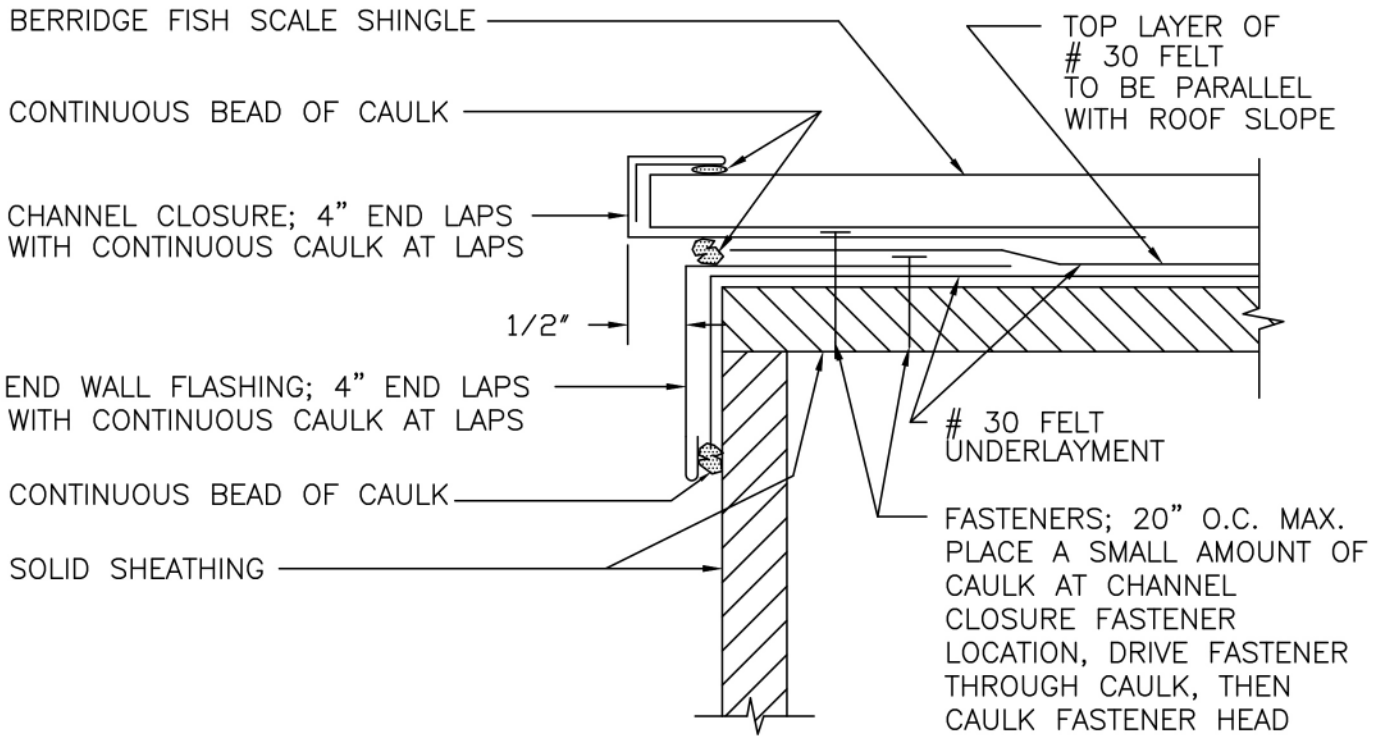

1. SOLID SHEATHING (BY OTHERS) TO BE MINIMUM 1/2" PLYWOOD OR EQUIVALENT IN STRENGTH FOR HOLDING POWER OF FASTENERS.
2. ALL FELT UNDERLAYMENT, CAULKING, AND FASTENERS, ARE ITEMS TO BE FURNISHED AND INSTALLED BY THE ROOFING INSTALLER AT THE DISCRETION OF THE ARCHITECT.

F = FINISH SIDE

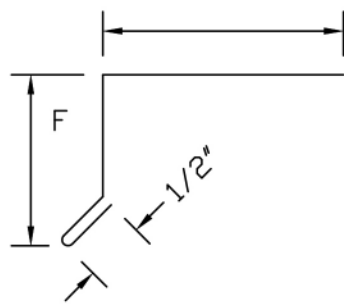

GABLE FLASHING

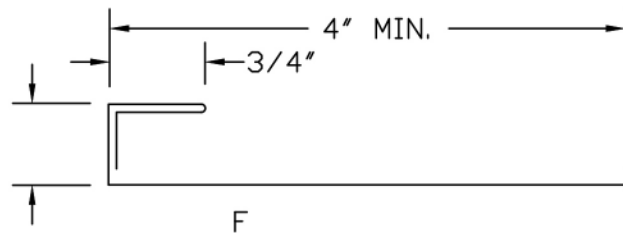

CHANNEL CLOSURE



**Berridge**  
**Manufacturing**  
**Company**

*Roofs of Distinction*

FASCIA END WALL

FISH SCALE SHINGLE

DATE: 03/22/08

PAGE\FILE

FSS-22

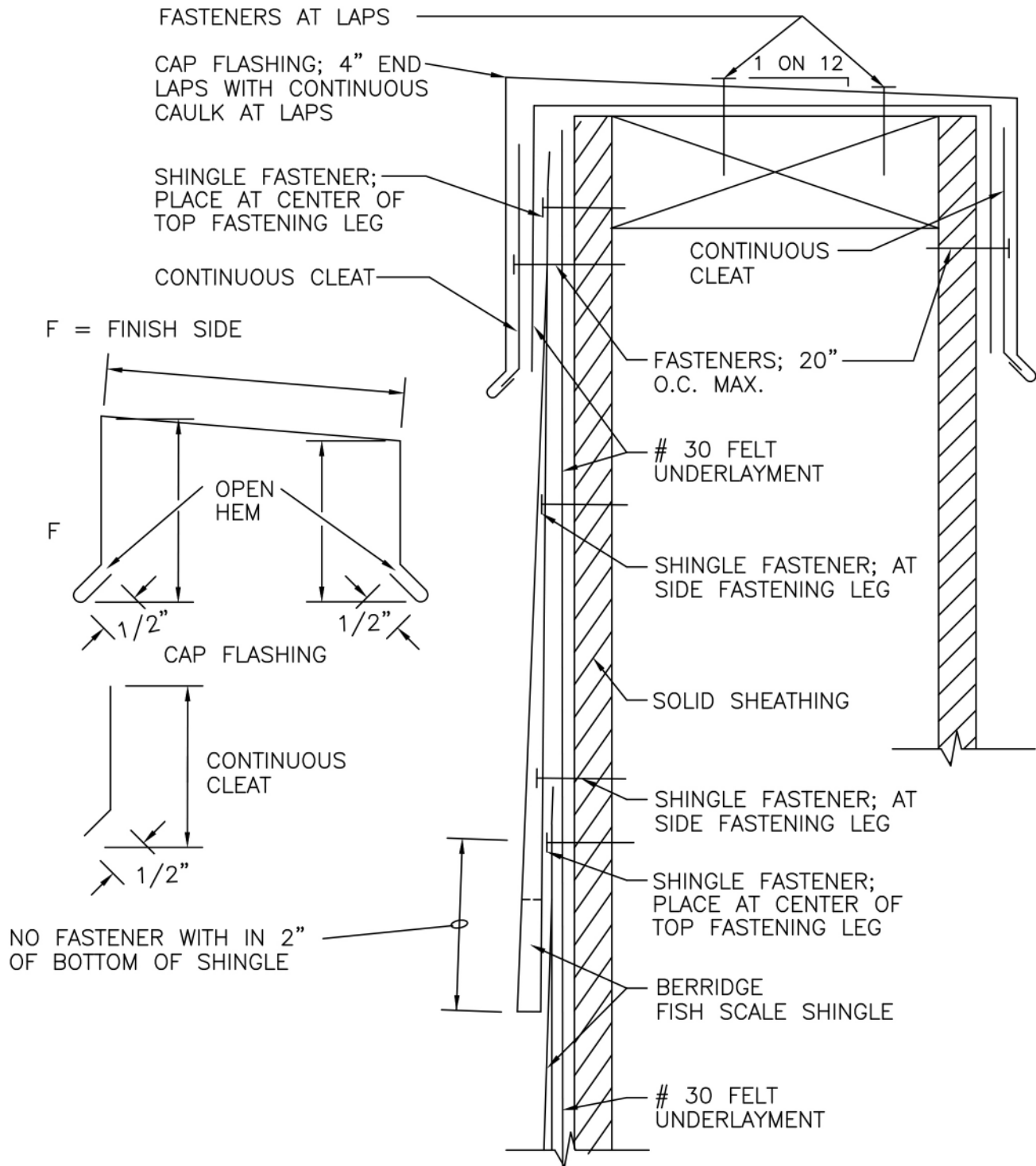

1. SOLID SHEATHING (BY OTHERS) TO BE MINIMUM 1/2" PLYWOOD OR EQUIVALENT IN STRENGTH FOR HOLDING POWER OF FASTENERS.
2. ALL FELT UNDERLAYMENT, CAULKING, AND FASTENERS, ARE ITEMS TO BE FURNISHED AND INSTALLED BY THE ROOFING INSTALLER AT THE DISCRETION OF THE ARCHITECT.

DATE: 03/22/08

---

PAGE\FILE  
**FSS-23**

FASCIA AT PARAPET

---

**FISH SCALE SHINGLE**

**Berridge  
Manufacturing  
Company**

*Roofs of Distinction*

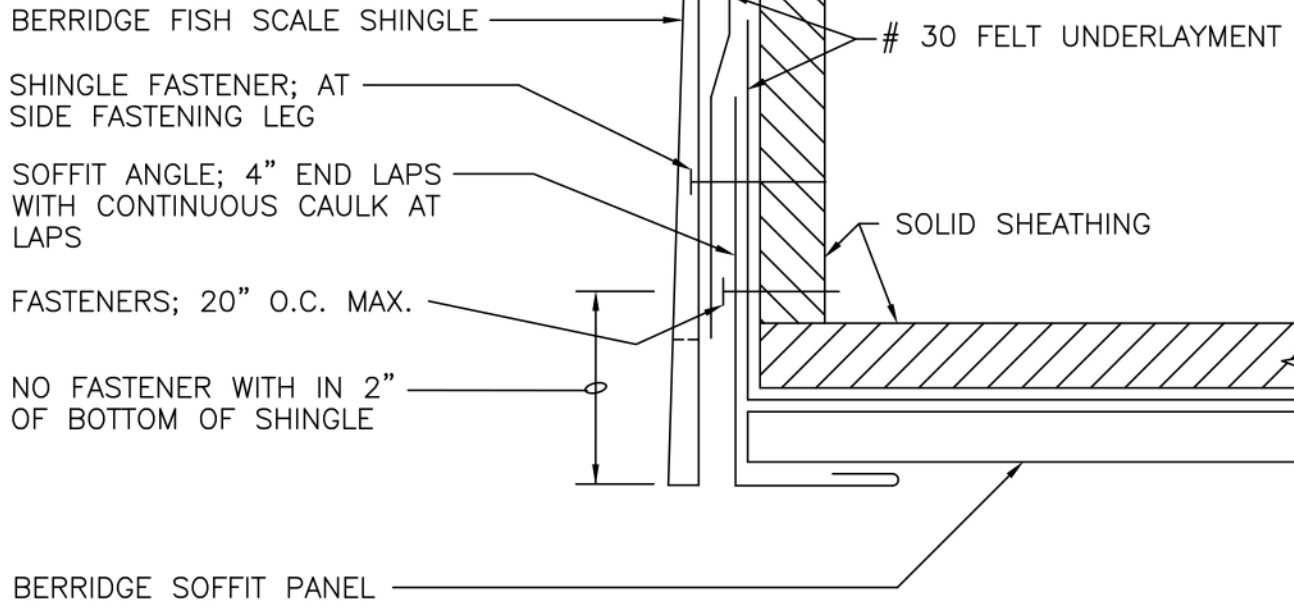

1. SOLID SHEATHING (BY OTHERS) TO BE MINIMUM 1/2" PLYWOOD OR EQUIVALENT IN STRENGTH FOR HOLDING POWER OF FASTENERS.
2. ALL FELT UNDERLAYMENT, CAULKING, AND FASTENERS, ARE ITEMS TO BE FURNISHED AND INSTALLED BY THE ROOFING INSTALLER AT THE DISCRETION OF THE ARCHITECT.

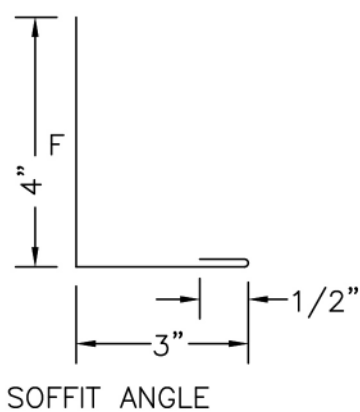

F = FINISH SIDE



**Berridge  
Manufacturing  
Company**

## FASCIA/SOFFIT DETAIL

### FISH SCALE SHINGLE

DATE: 03/22/08

PAGE\FILE

**FSS-30**

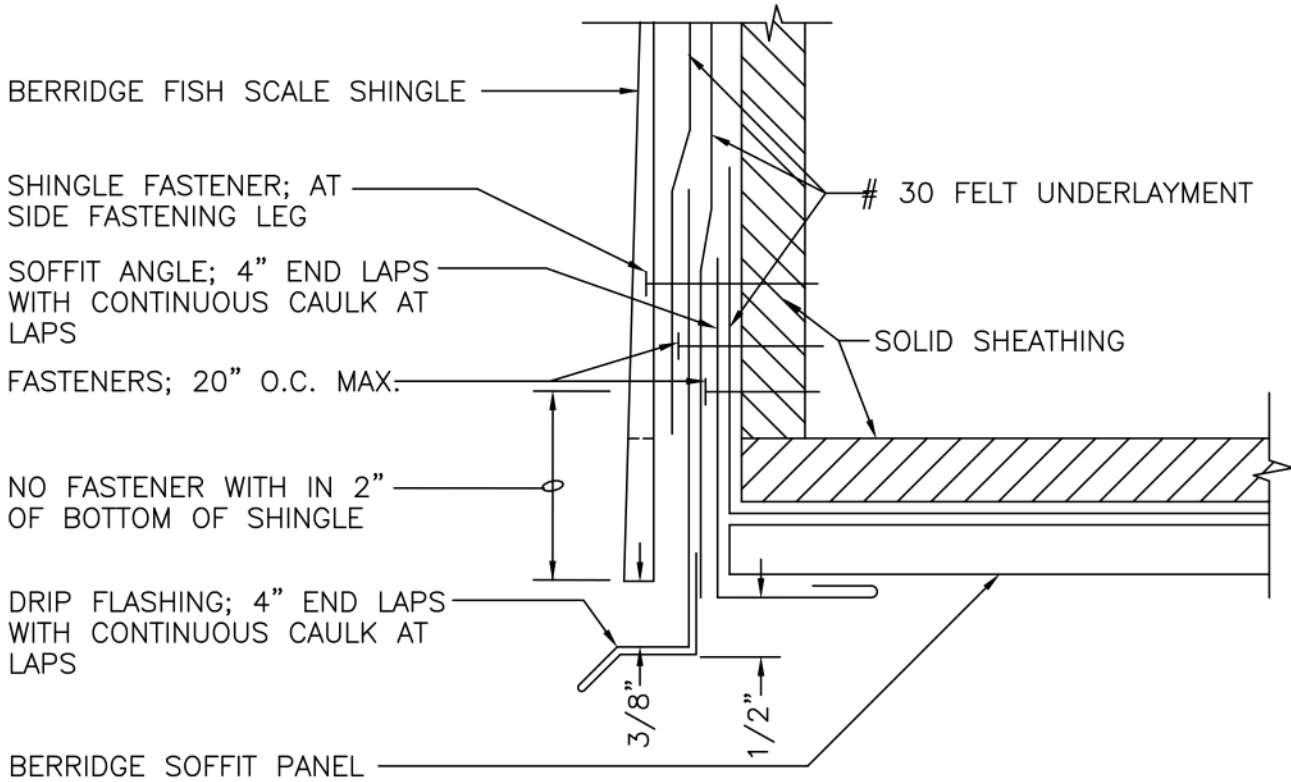

1. SOLID SHEATHING (BY OTHERS) TO BE MINIMUM 1/2" PLYWOOD OR EQUIVALENT IN STRENGTH FOR HOLDING POWER OF FASTENERS.
2. ALL FELT UNDERLAYMENT, CAULKING, AND FASTENERS, ARE ITEMS TO BE FURNISHED AND INSTALLED BY THE ROOFING INSTALLER AT THE DISCRETION OF THE ARCHITECT.

F = FINISH SIDE

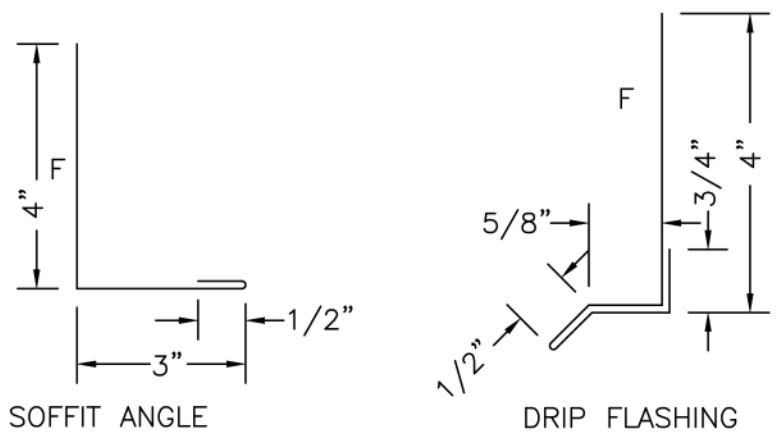

DATE: 03/22/08  
 PAGE\FILE  
**FSS-3I**

FASCIA/SOFFIT DETAIL  
**FISH SCALE SHINGLE**

**Berridge**  
 Manufacturing  
 Company  
*Roofs of Distinction*

SOLID SHEATHING

BERRIDGE SOFFIT PANEL

# 30 FELT UNDERLAYMENT

SOFFIT ANGLE; 4" END LAPS WITH CONTINUOUS CAULK AT LAPS, POP RIVET TO PANELS 20" O.C.

FASTENERS; AT SHINGLE

BERRIDGE FISH SCALE SHINGLE

# 30 FELT UNDERLAYMENT

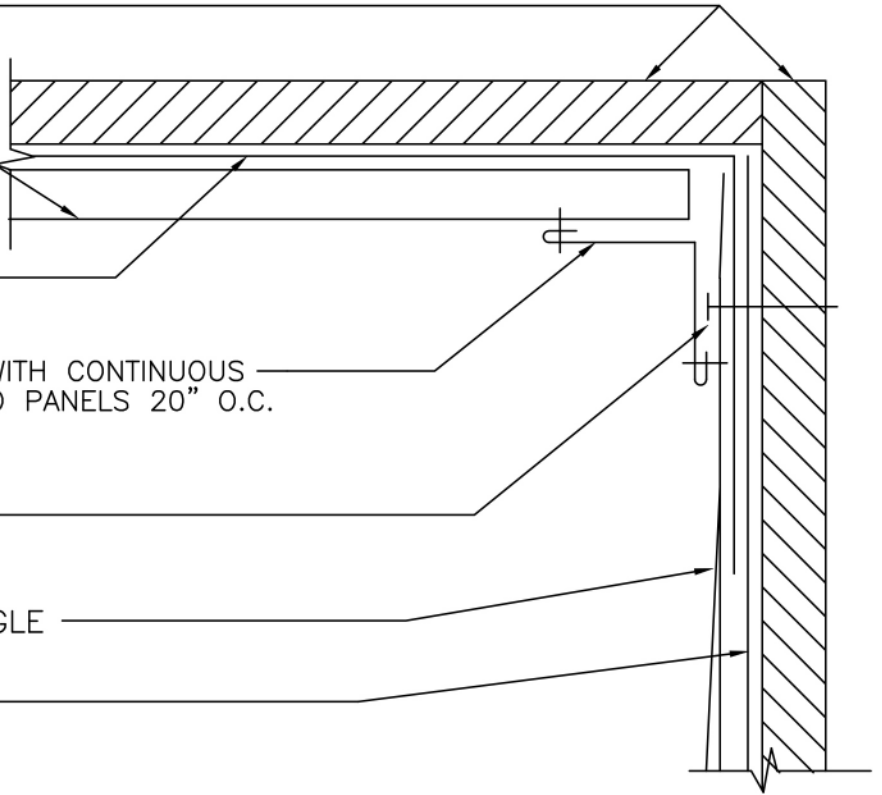

1. SOLID SHEATHING (BY OTHERS) TO BE MINIMUM 1/2" PLYWOOD OR EQUIVALENT IN STRENGTH FOR HOLDING POWER OF FASTENERS.
2. ALL FELT UNDERLAYMENT, CAULKING, AND FASTENERS, ARE ITEMS TO BE FURNISHED AND INSTALLED BY THE ROOFING INSTALLER AT THE DISCRETION OF THE ARCHITECT.

F = FINISH SIDE

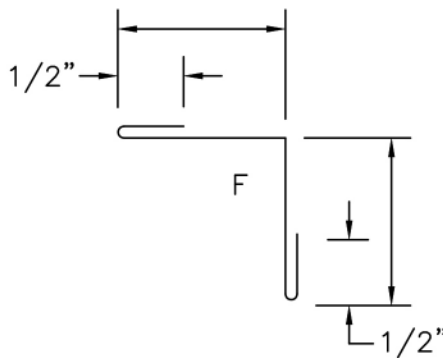

SOFFIT ANGLE



Berridge Manufacturing Company

# WALL/SOFFIT DETAIL

## FISH SCALE SHINGLE

DATE: 03/22/08

PAGE\FILE

FSS-32

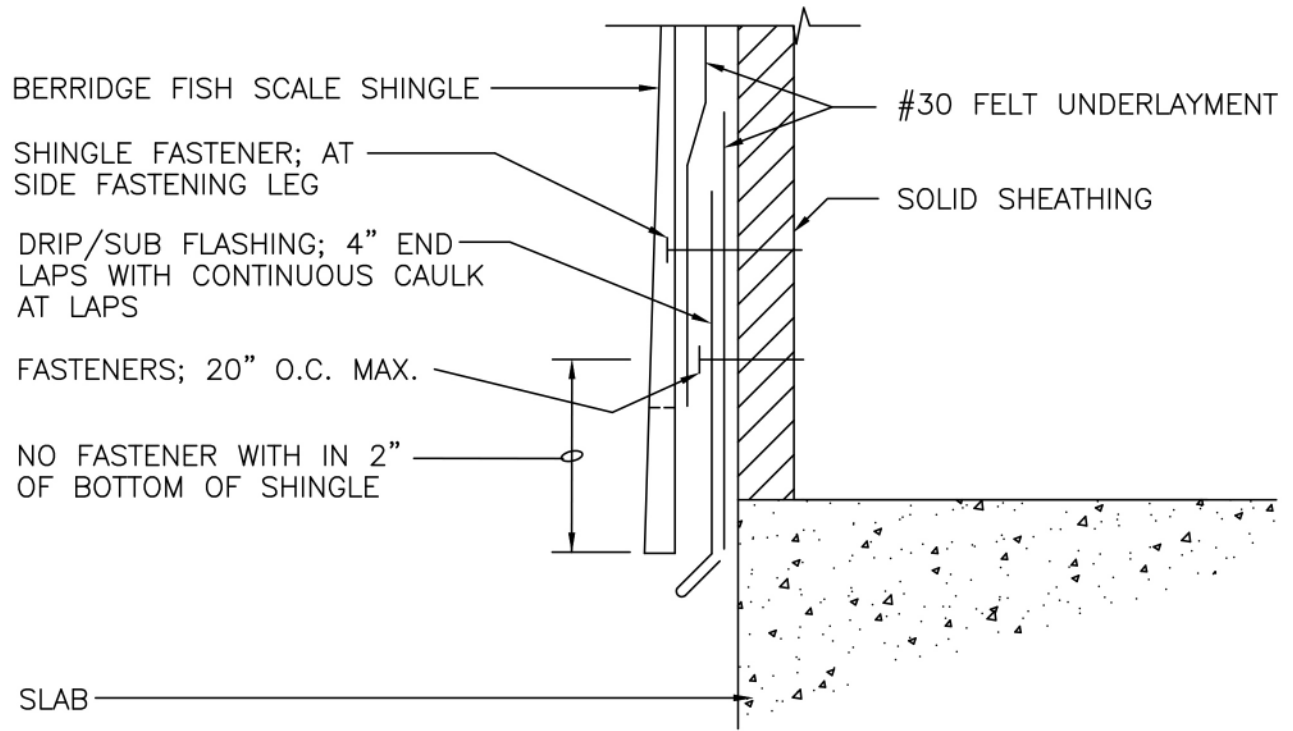

1. SOLID SHEATHING (BY OTHERS) TO BE MINIMUM 1/2" PLYWOOD OR EQUIVALENT IN STRENGTH FOR HOLDING POWER OF FASTENERS.
2. ALL FELT UNDERLAYMENT, CAULKING, AND FASTENERS, ARE ITEMS TO BE FURNISHED AND INSTALLED BY THE ROOFING INSTALLER AT THE DISCRETION OF THE ARCHITECT.

F = FINISH SIDE

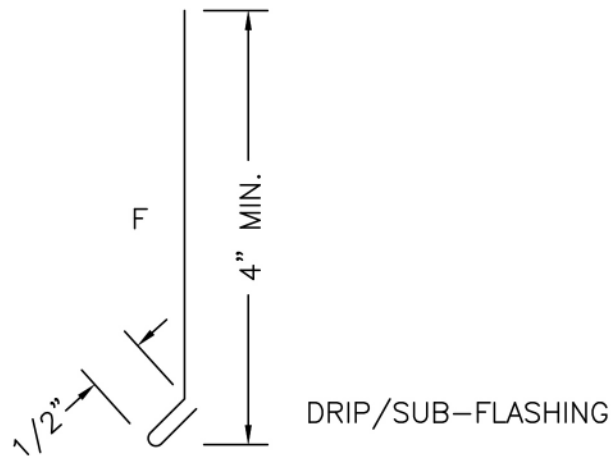

**Berridge**  
Manufacturing  
Company

SILL AT SLAB DETAIL

FISH SCALE SHINGLE

DATE: 03/22/08

PAGE\FILE

FSS-40



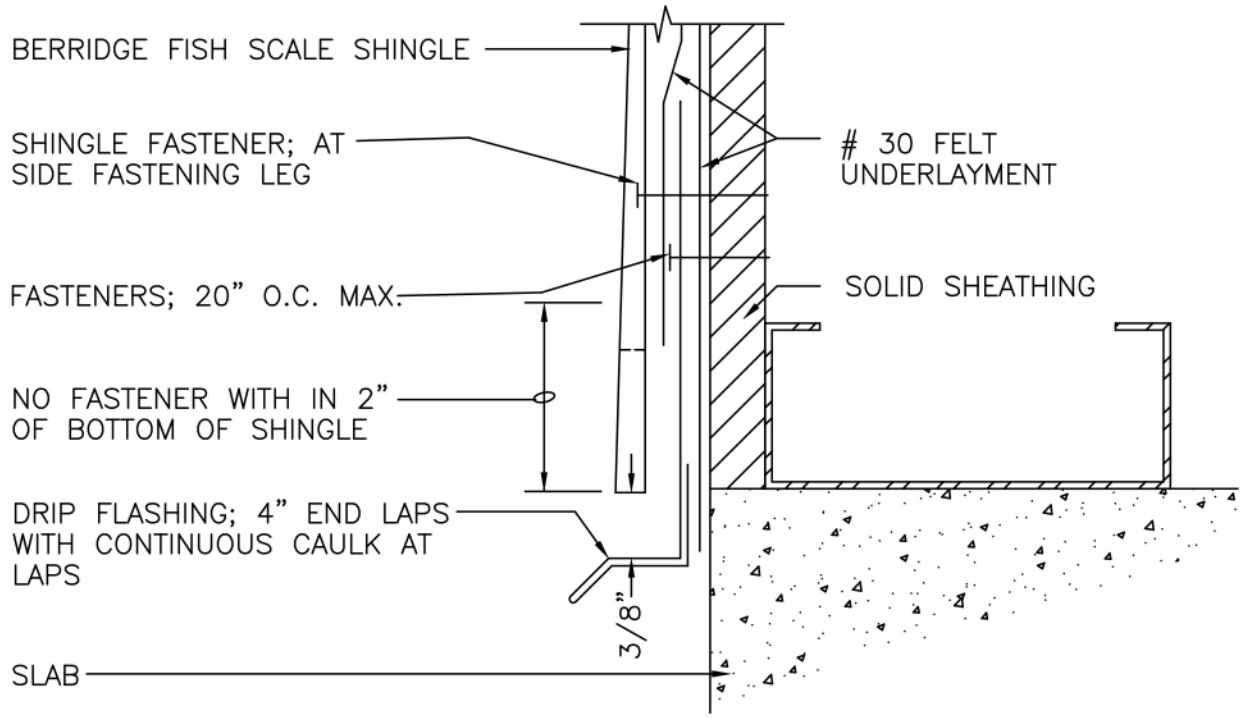

1. SOLID SHEATHING (BY OTHERS) TO BE MINIMUM 1/2" PLYWOOD OR EQUIVALENT IN STRENGTH FOR HOLDING POWER OF FASTENERS.
2. ALL FELT UNDERLAYMENT, CAULKING, AND FASTENERS, ARE ITEMS TO BE FURNISHED AND INSTALLED BY THE ROOFING INSTALLER AT THE DISCRETION OF THE ARCHITECT.

F = FINISH SIDE

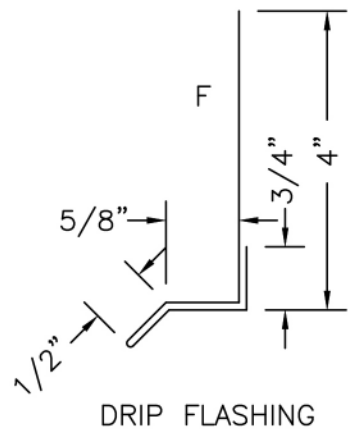

DATE: 03/22/08  
 PAGE\FILE  
**FSS-4I**

SILL AT SLAB DETAIL  
**FISH SCALE SHINGLE**

**Berridge Manufacturing Company**  
*Roofs of Distinction*

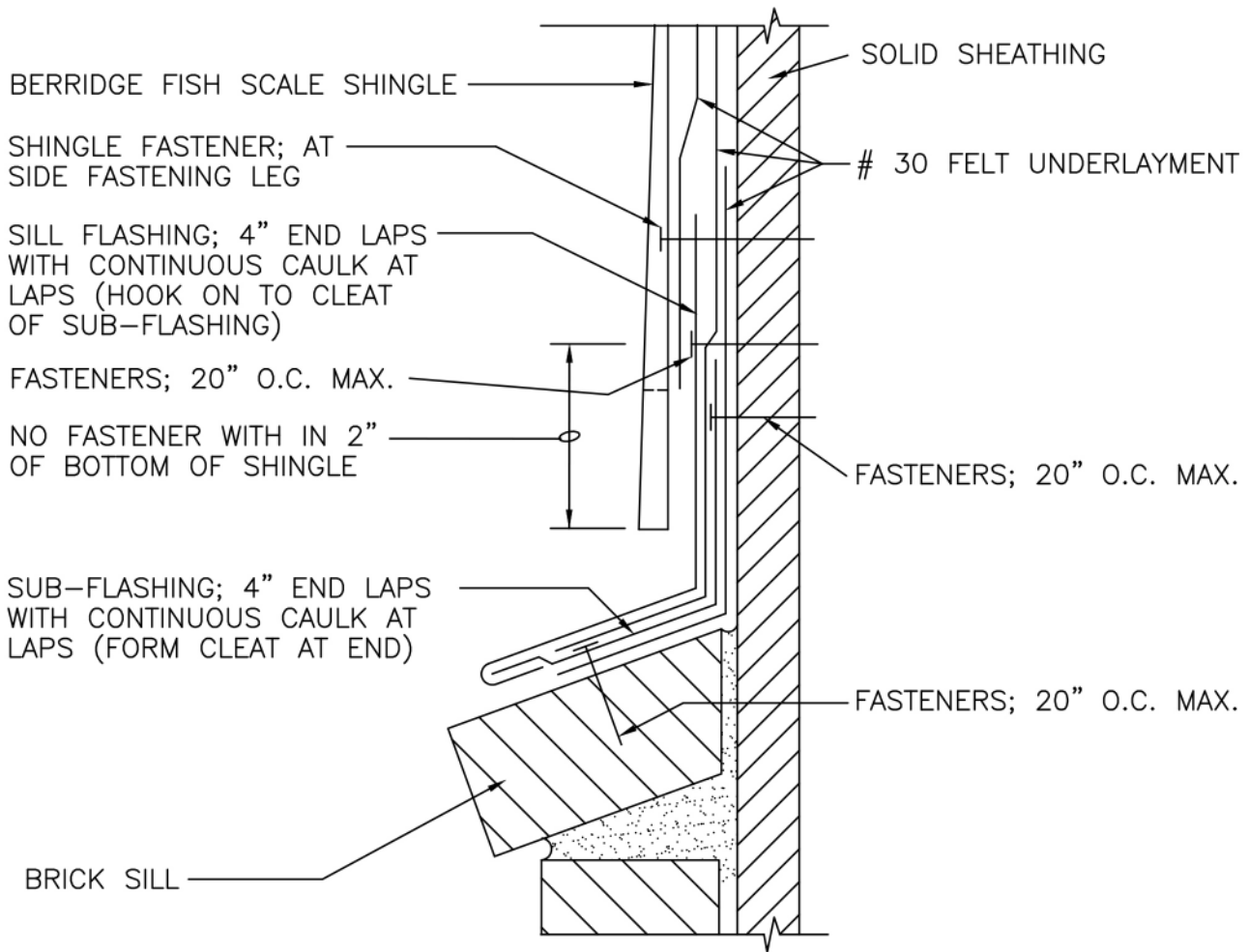

1. SOLID SHEATHING (BY OTHERS) TO BE MINIMUM 1/2" PLYWOOD OR EQUIVALENT IN STRENGTH FOR HOLDING POWER OF FASTENERS.
2. ALL FELT UNDERLAYMENT, CAULKING, AND FASTENERS, ARE ITEMS TO BE FURNISHED AND INSTALLED BY THE ROOFING INSTALLER AT THE DISCRETION OF THE ARCHITECT.

F = FINISH SIDE

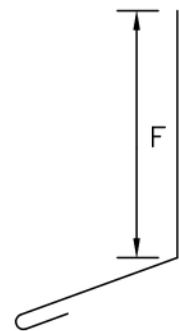

SILL FLASHING

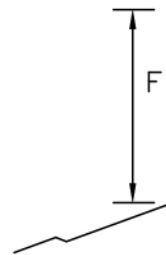

SUB-FLASHING



**Berridge**  
Manufacturing  
Company

*Roofs of Distinction*

SILL AT BRICK DETAIL

FISH SCALE SHINGLE

DATE: 03/22/08

PAGE\FILE

FSS-42

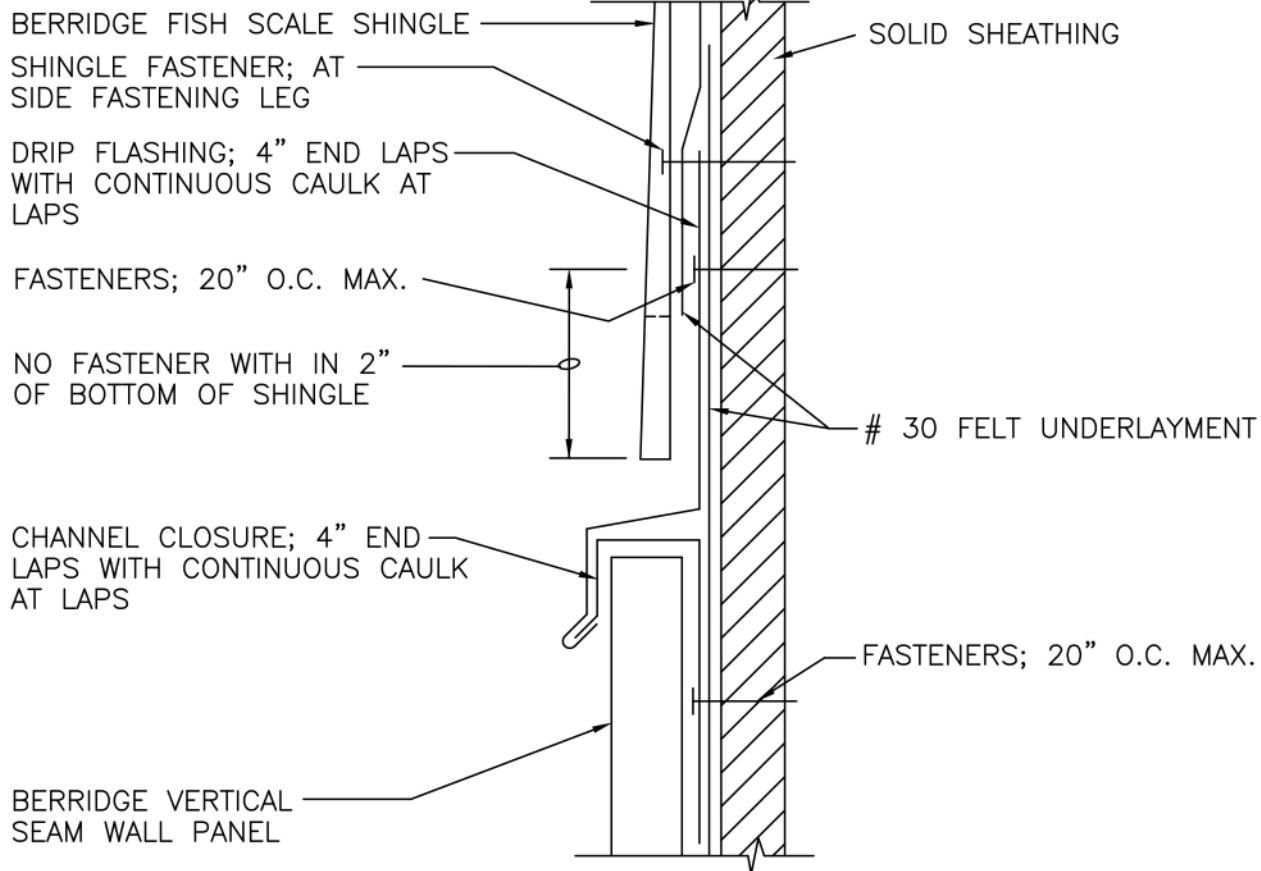

1. SOLID SHEATHING (BY OTHERS) TO BE MINIMUM 1/2" PLYWOOD OR EQUIVALENT IN STRENGTH FOR HOLDING POWER OF FASTENERS.
2. ALL FELT UNDERLAYMENT, CAULKING, AND FASTENERS, ARE ITEMS TO BE FURNISHED AND INSTALLED BY THE ROOFING INSTALLER AT THE DISCRETION OF THE ARCHITECT.

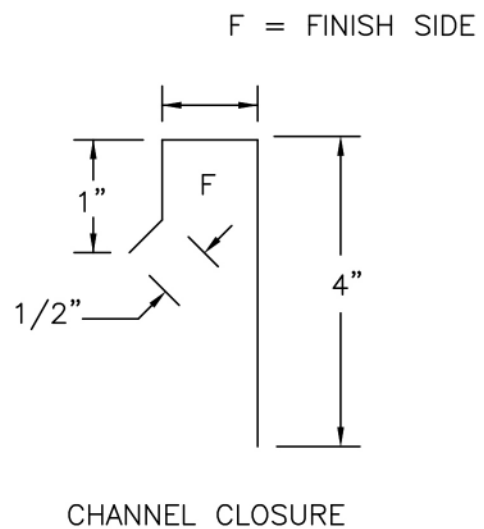
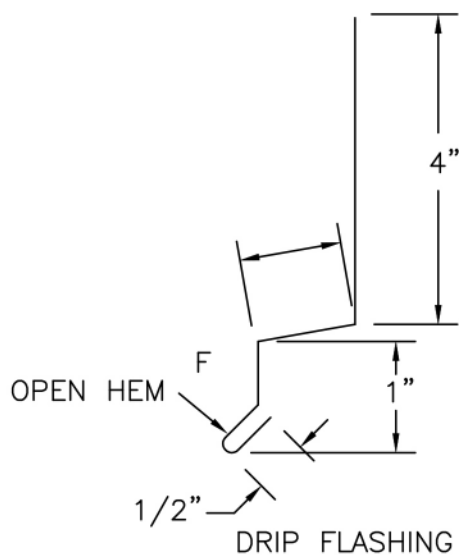

DATE: 03/22/08

SILL AT VERTICAL PANEL

PAGE\FILE

FSS-43

FISH SCALE SHINGLE



Berridge  
Manufacturing  
Company

Roofs of Distinction

BERRIDGE FISH SCALE SHINGLE

SHINGLE FASTENER; AT SIDE FASTENING LEG

DRIP FLASHING; 4" END LAPS WITH CONTINUOUS CAULK AT LAPS

FASTENERS; 20" O.C. MAX.

NO FASTENER WITH IN 2" OF BOTTOM OF SHINGLE

# 30 FELT UNDERLAYMENT

SOLID SHEATHING

HEAD

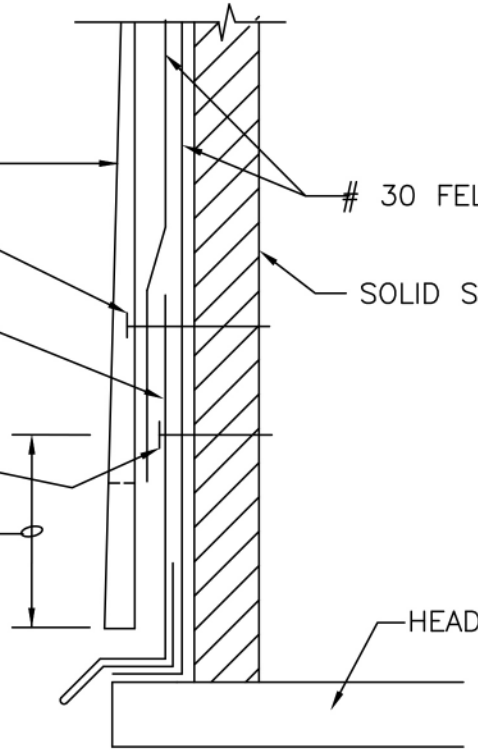

1. SOLID SHEATHING (BY OTHERS) TO BE MINIMUM 1/2" PLYWOOD OR EQUIVALENT IN STRENGTH FOR HOLDING POWER OF FASTENERS.
2. ALL FELT UNDERLAYMENT, CAULKING, AND FASTENERS, ARE ITEMS TO BE FURNISHED AND INSTALLED BY THE ROOFING INSTALLER AT THE DISCRETION OF THE ARCHITECT.

F = FINISH SIDE

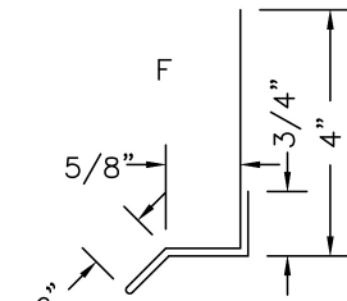

DRIP FLASHING



Berridge Manufacturing Company

# HEADER DETAIL

## FISH SCALE SHINGLE

DATE: 03/22/08

PAGE\FILE  
FSS-50

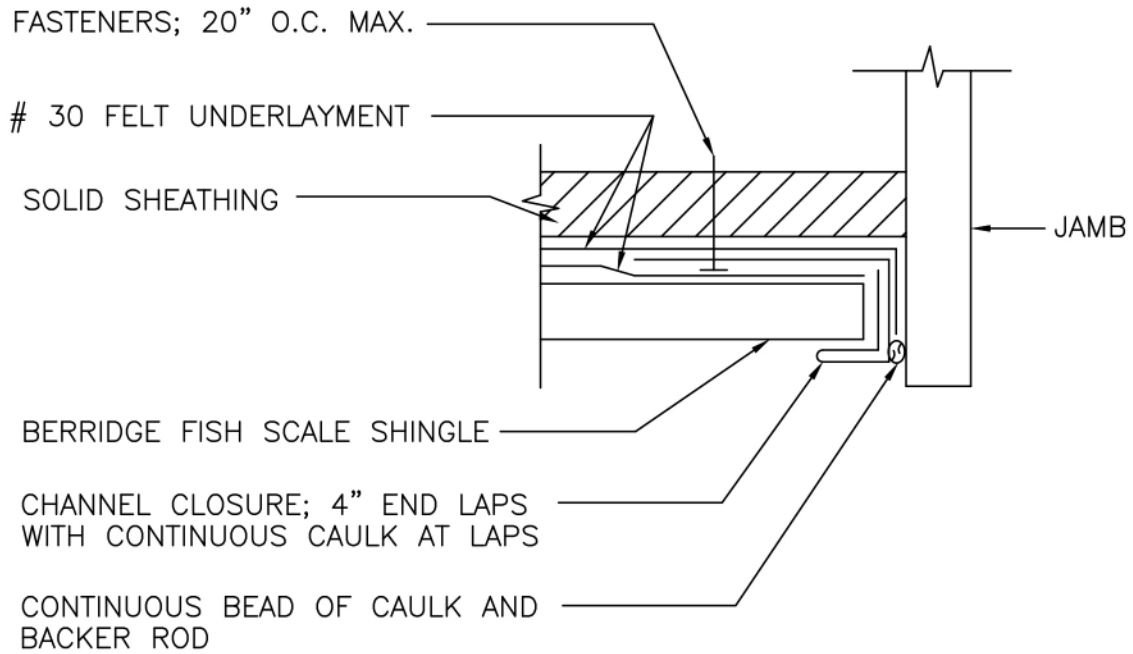

1. SOLID SHEATHING (BY OTHERS) TO BE MINIMUM 1/2" PLYWOOD OR EQUIVALENT IN STRENGTH FOR HOLDING POWER OF FASTENERS.
2. ALL FELT UNDERLAYMENT, CAULKING, AND FASTENERS, ARE ITEMS TO BE FURNISHED AND INSTALLED BY THE ROOFING INSTALLER AT THE DISCRETION OF THE ARCHITECT.

F = FINISH SIDE

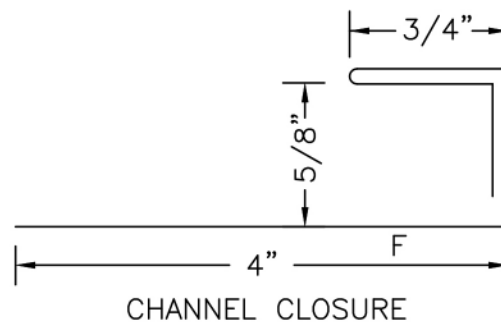

DATE: 03/22/08

WINDOW/DOOR JAMB

PAGE\FILE

FSS-51

FISH SCALE SHINGLE



Berridge  
Manufacturing  
Company

*Roofs of Distinction*

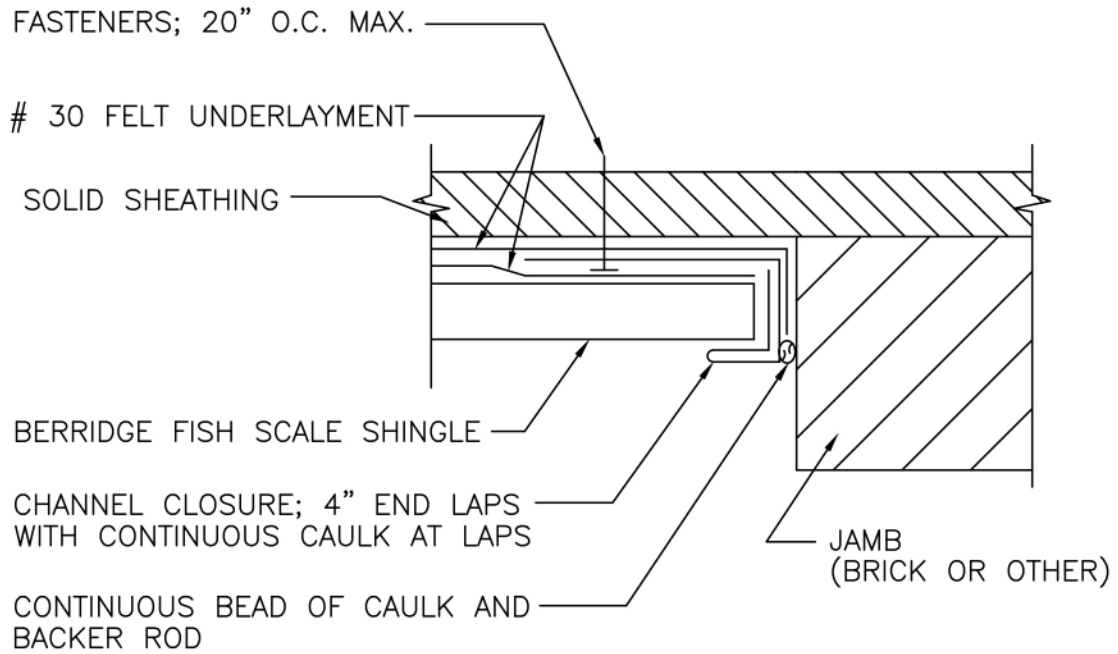

1. SOLID SHEATHING (BY OTHERS) TO BE MINIMUM 1/2" PLYWOOD OR EQUIVALENT IN STRENGTH FOR HOLDING POWER OF FASTENERS.
2. ALL FELT UNDERLAYMENT, CAULKING, AND FASTENERS, ARE ITEMS TO BE FURNISHED AND INSTALLED BY THE ROOFING INSTALLER AT THE DISCRETION OF THE ARCHITECT.

F = FINISH SIDE

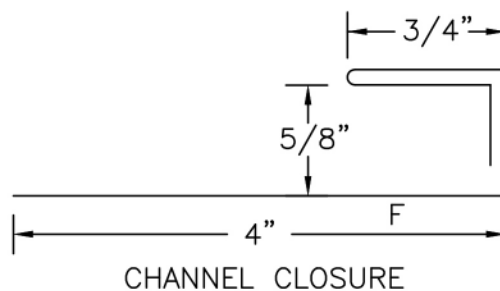

**Berridge**  
Manufacturing  
Company

*Roofs of Distinction*

## JAMB DETAIL

FISH SCALE SHINGLE

DATE: 03/22/08

PAGE\FILE

FSS-52

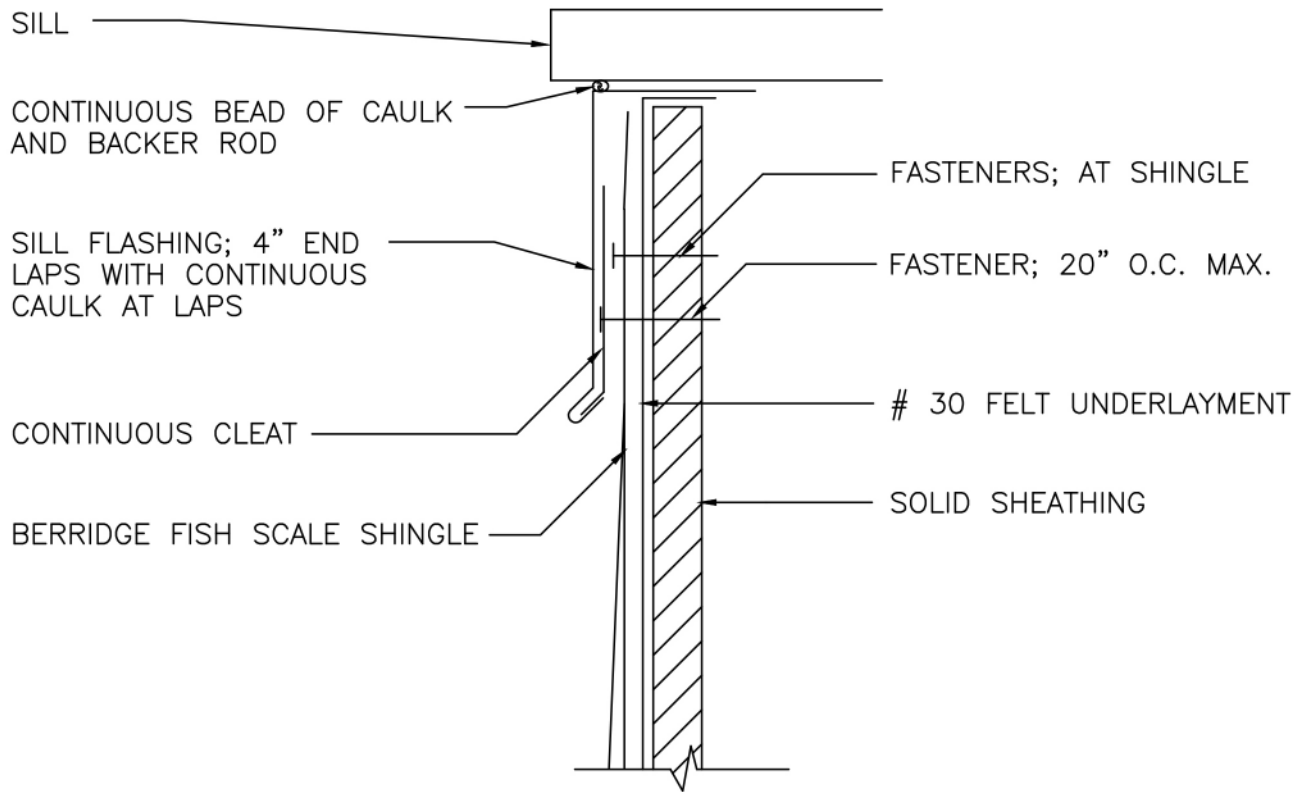

1. SOLID SHEATHING (BY OTHERS) TO BE MINIMUM 1/2" PLYWOOD OR EQUIVALENT IN STRENGTH FOR HOLDING POWER OF FASTENERS.
2. ALL FELT UNDERLAYMENT, CAULKING, AND FASTENERS, ARE ITEMS TO BE FURNISHED AND INSTALLED BY THE ROOFING INSTALLER AT THE DISCRETION OF THE ARCHITECT.

F = FINISH SIDE

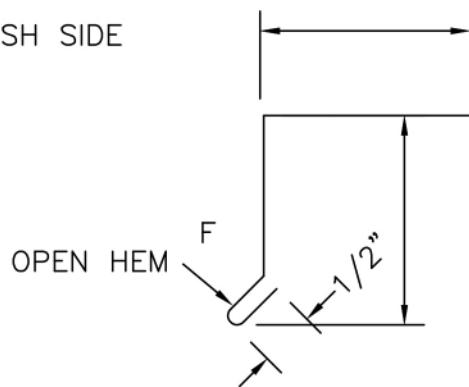

SILL FLASHING

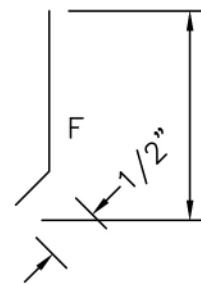

CONTINUOUS CLEAT

DATE: 03/22/08

## SILL DETAIL

PAGE\FILE

FSS-53

## FISH SCALE SHINGLE



Berridge  
Manufacturing  
Company

*Roofs of Distinction*

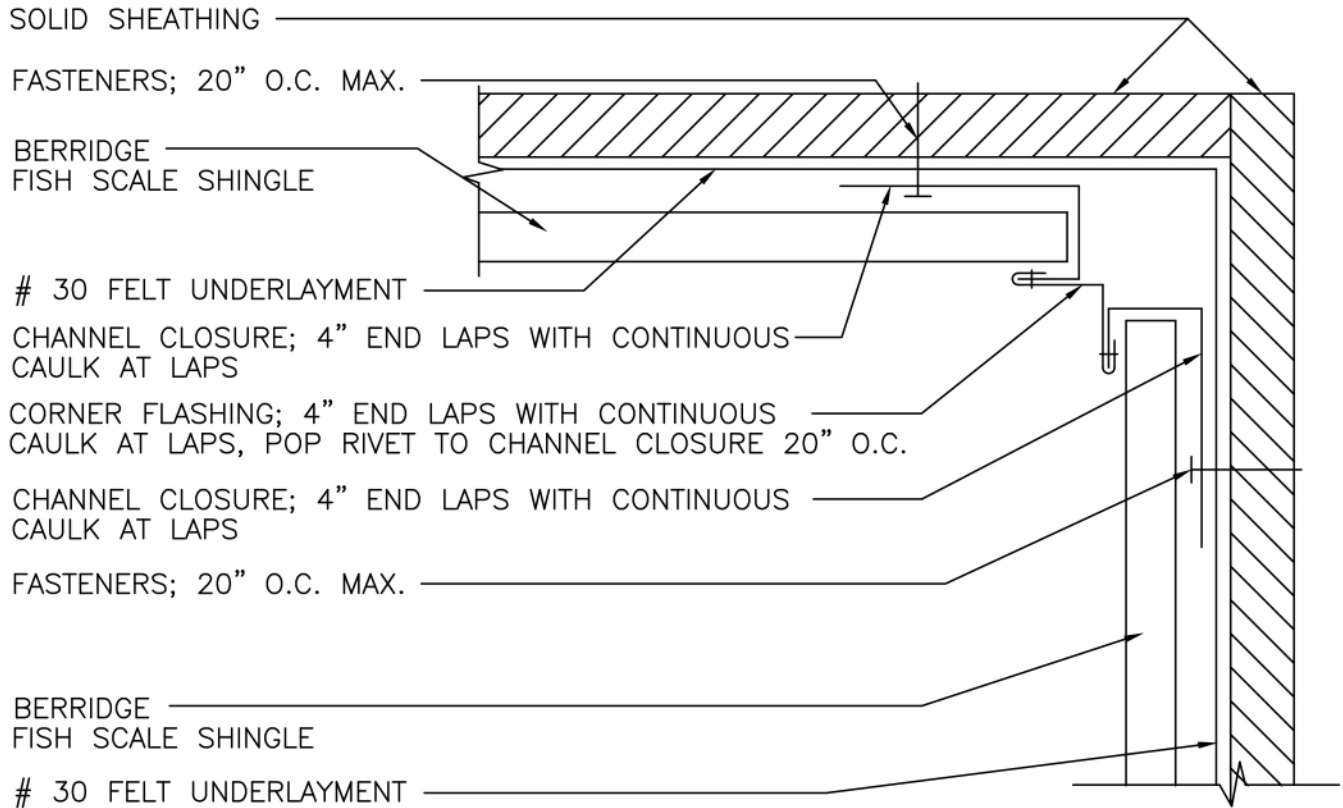

1. SOLID SHEATHING (BY OTHERS) TO BE MINIMUM 1/2" PLYWOOD OR EQUIVALENT IN STRENGTH FOR HOLDING POWER OF FASTENERS.
2. ALL FELT UNDERLAYMENT, CAULKING, AND FASTENERS, ARE ITEMS TO BE FURNISHED AND INSTALLED BY THE ROOFING INSTALLER AT THE DISCRETION OF THE ARCHITECT.

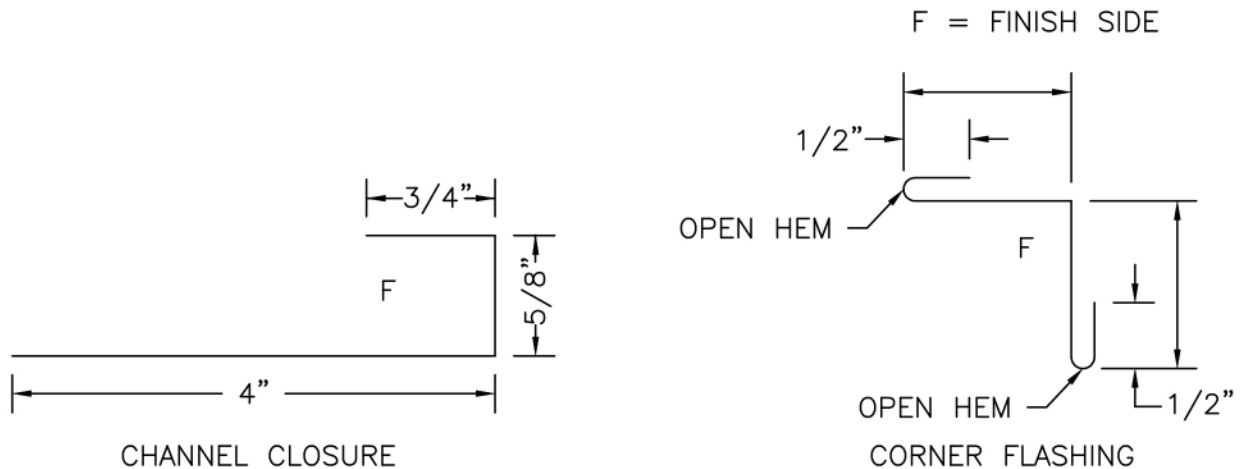

**Berridge  
Manufacturing  
Company**

## INSIDE CORNER DETAIL

**FISH SCALE SHINGLE**

DATE: 03/22/08

PAGE\FILE

**FSS-60**



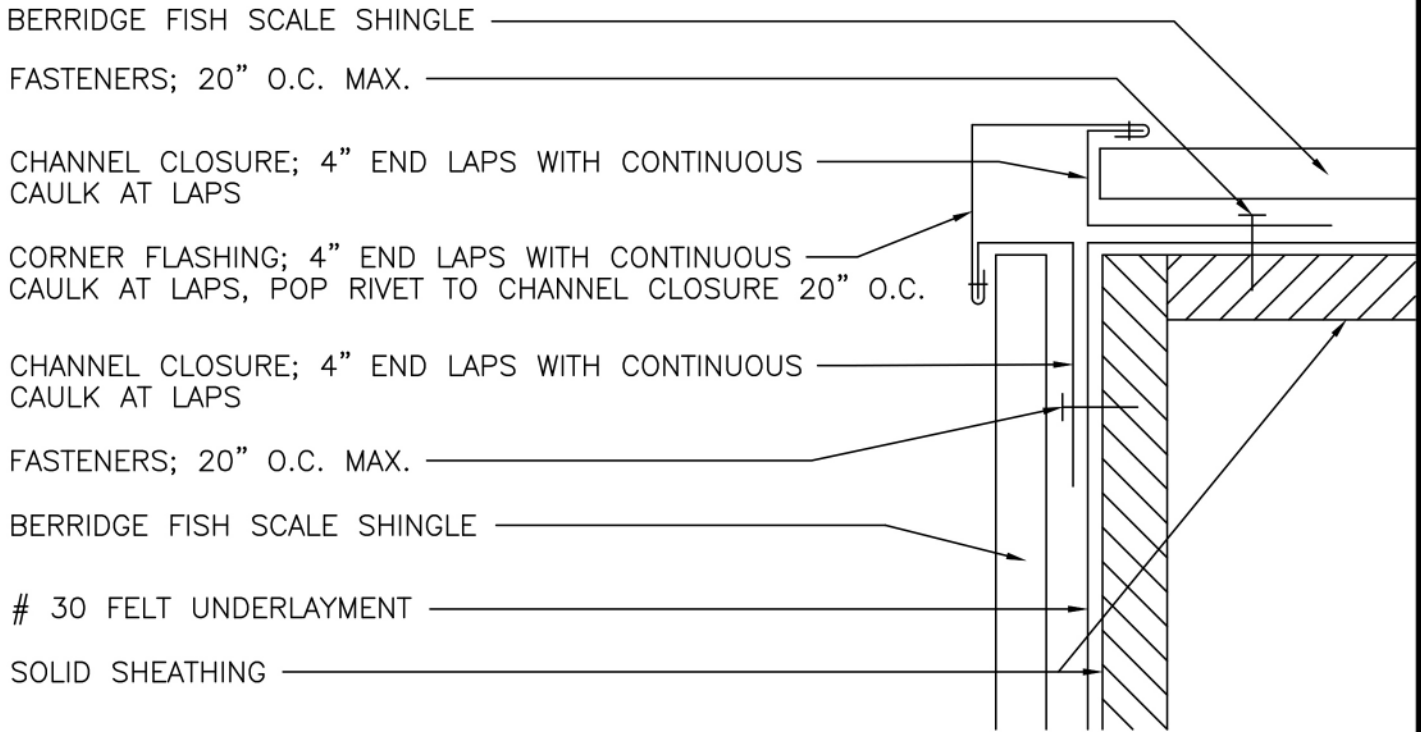

1. SOLID SHEATHING (BY OTHERS) TO BE MINIMUM 1/2" PLYWOOD OR EQUIVALENT IN STRENGTH FOR HOLDING POWER OF FASTENERS.
2. ALL FELT UNDERLAYMENT, CAULKING, AND FASTENERS, ARE ITEMS TO BE FURNISHED AND INSTALLED BY THE ROOFING INSTALLER AT THE DISCRETION OF THE ARCHITECT.

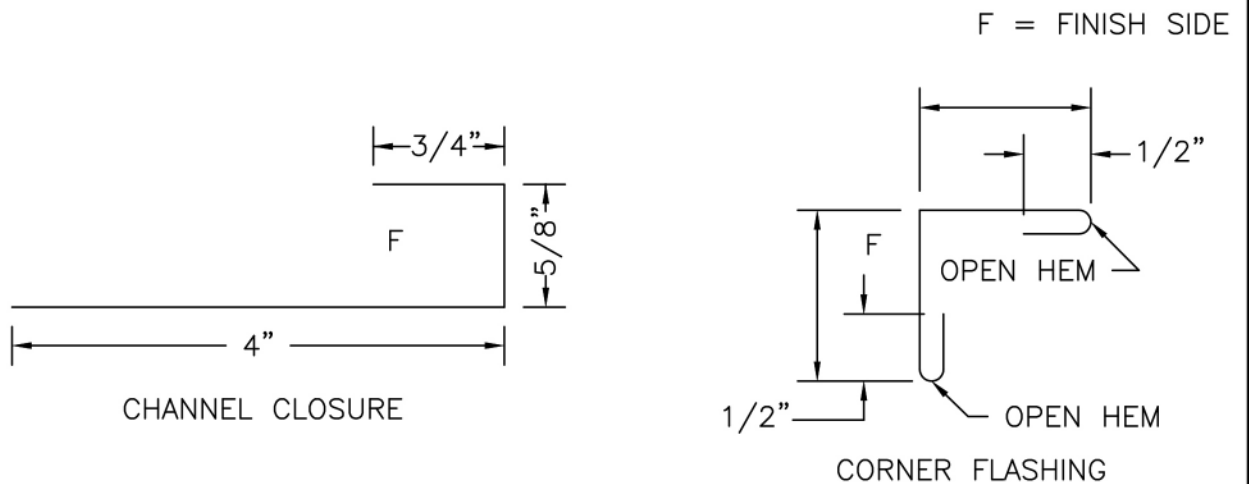

DATE: 03/22/08

## OUTSIDE CORNER DETAIL

PAGE\FILE

**FSS-61**

## FISH SCALE SHINGLE



**Berridge  
Manufacturing  
Company**

*Roofs of Distinction*

CAP FLASHING; 4" END LAPS WITH CONTINUOUS CAULK AT LAPS

SLOPE 1:12 MIN.  
FASTENERS AT LAPS AND STAGGERED 20" O.C. MAX. CAULK FASTENER HEADS

FASTENERS; AT SHINGLE

FASTENER; 20" O.C. MAX.

FASTENER; 20" O.C. MAX.

CONTINUOUS CLEAT

CONTINUOUS CLEAT

# 30 FELT UNDERLAYMENT

BERRIDGE FISH SCALE SHINGLE

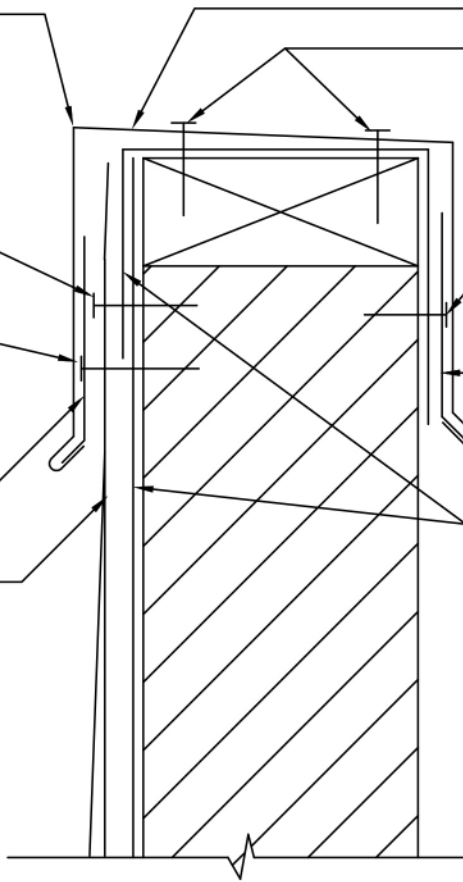

1. SOLID SHEATHING (BY OTHERS) TO BE MINIMUM 1/2" PLYWOOD OR EQUIVALENT IN STRENGTH FOR HOLDING POWER OF FASTENERS.
2. ALL FELT UNDERLAYMENT, CAULKING, AND FASTENERS, ARE ITEMS TO BE FURNISHED AND INSTALLED BY THE ROOFING INSTALLER AT THE DISCRETION OF THE ARCHITECT.

F = FINISH SIDE

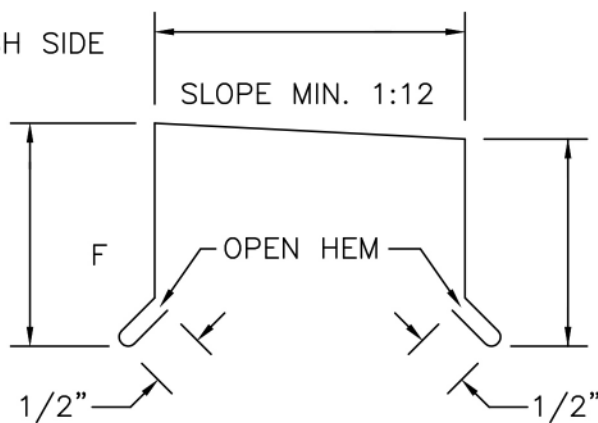

CAP FLASHING

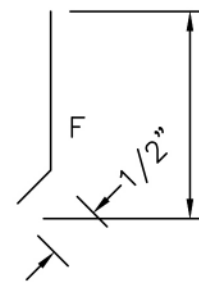

CONTINUOUS CLEAT



**Berridge**  
Manufacturing  
Company

## PARAPET DETAIL

### FISH SCALE SHINGLE

DATE: 03/22/08

PAGE\FILE

FSS-70

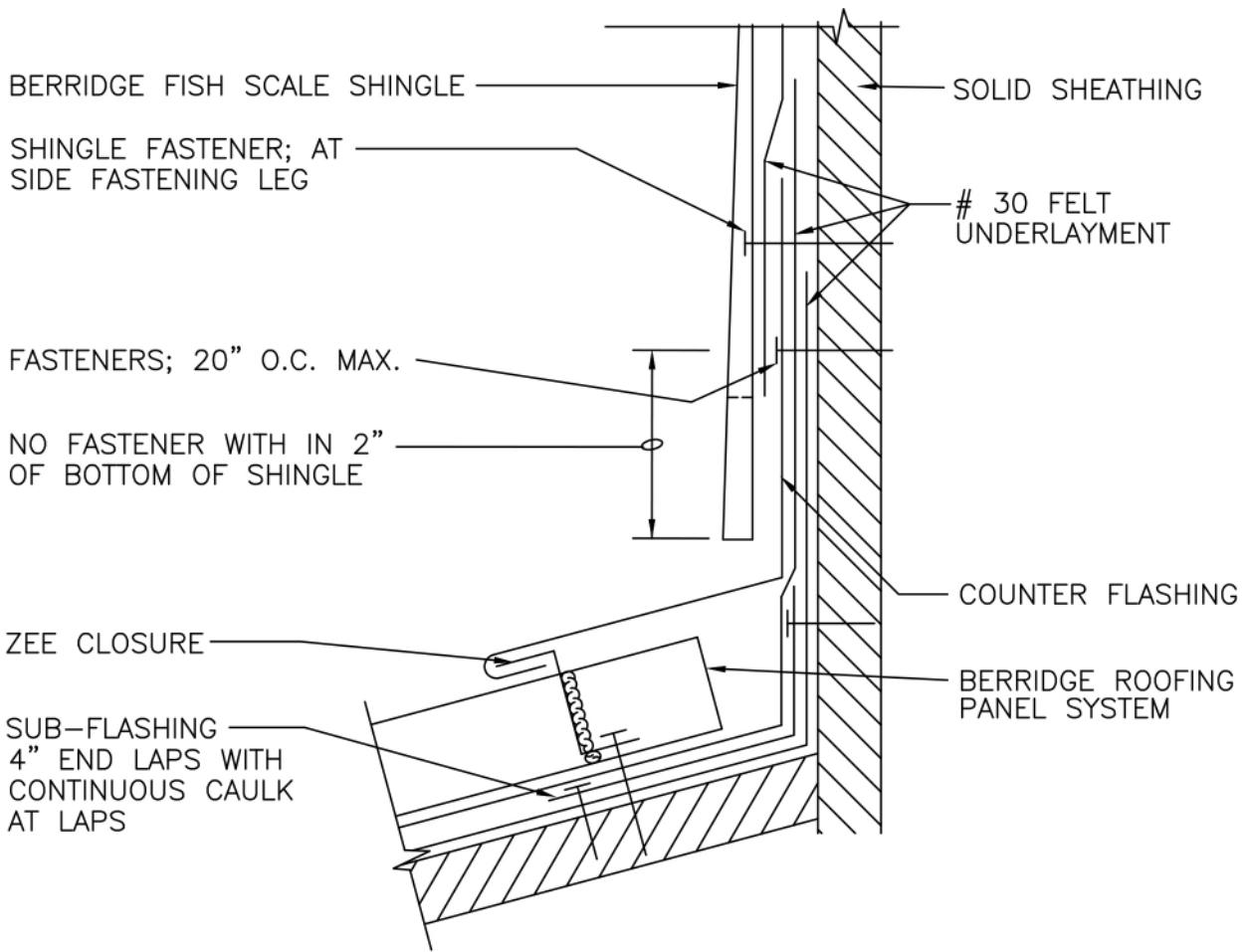

1. SOLID SHEATHING (BY OTHERS) TO BE MINIMUM 1/2" PLYWOOD OR EQUIVALENT IN STRENGTH FOR HOLDING POWER OF FASTENERS.
2. ALL FELT UNDERLAYMENT, CAULKING, AND FASTENERS, ARE ITEMS TO BE FURNISHED AND INSTALLED BY THE ROOFING INSTALLER AT THE DISCRETION OF THE ARCHITECT.

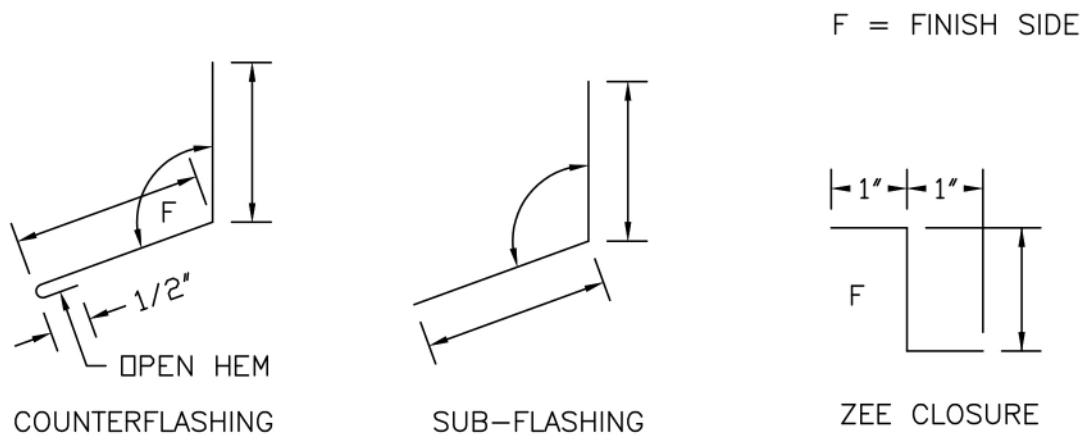

DATE: 03/22/08

## HEAD WALL DETAIL

PAGE\FILE

FSS-71

## FISH SCALE SHINGLE



**Berridge**  
Manufacturing  
Company

*Roofs of Distinction*

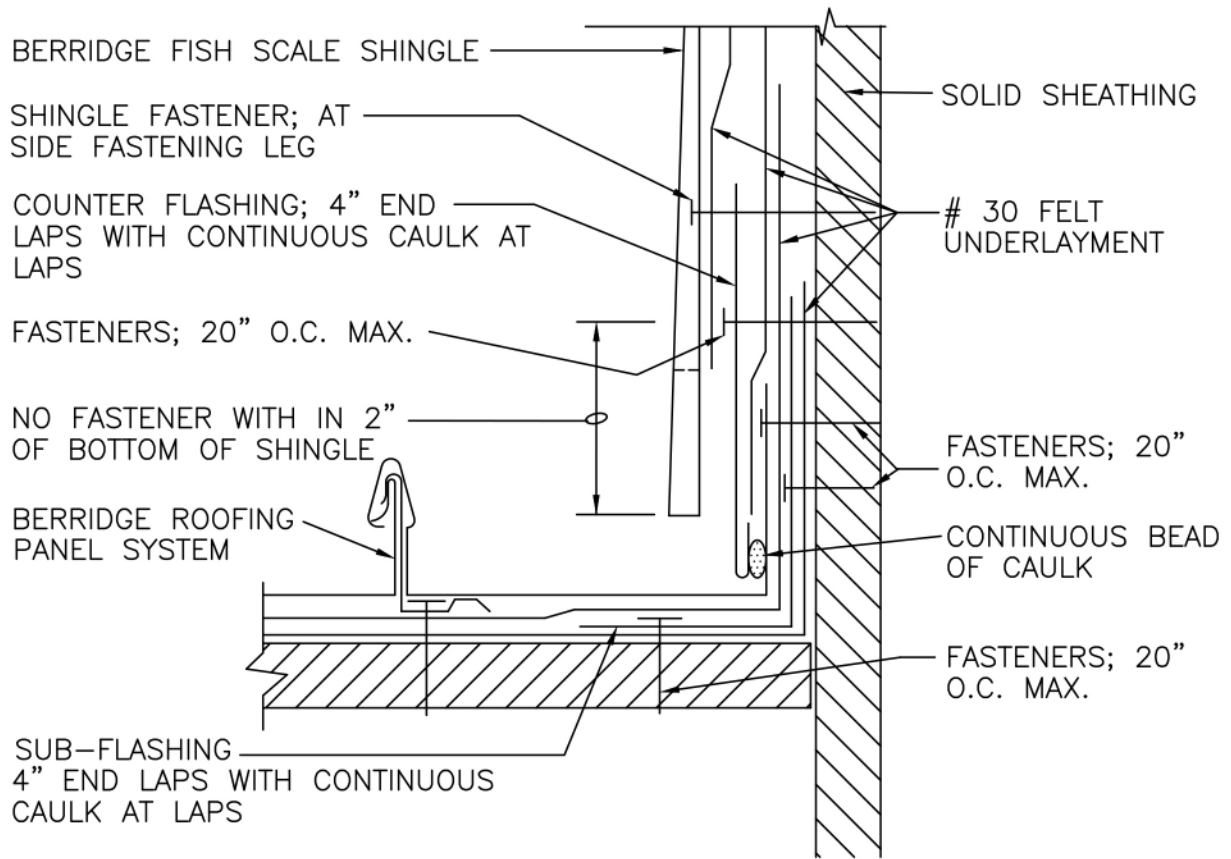

1. SOLID SHEATHING (BY OTHERS) TO BE MINIMUM 1/2" PLYWOOD OR EQUIVALENT IN STRENGTH FOR HOLDING POWER OF FASTENERS.
2. ALL FELT UNDERLAYMENT, CAULKING, AND FASTENERS, ARE ITEMS TO BE FURNISHED AND INSTALLED BY THE ROOFING INSTALLER AT THE DISCRETION OF THE ARCHITECT.

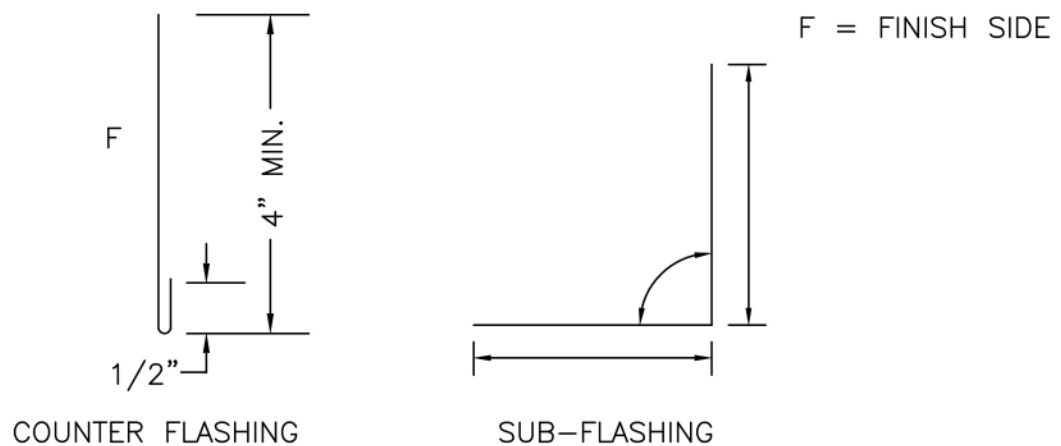

**Berridge  
Manufacturing  
Company**

*Roofs of Distinction*

## RAKE WALL DETAIL

### FISH SCALE SHINGLE

DATE: 03/22/08

PAGE\FILE

**FSS-72**