

Berridge Folding Tee-Clip

FOR USE WITH TEE-PANEL & HIGH SEAM TEE-PANEL

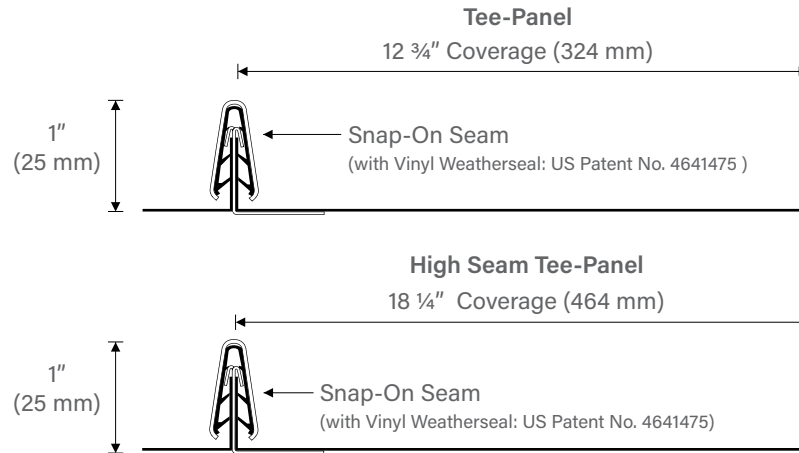

Materials

28 Gauge Steel

Installation

- Install per Berridge Installation Details
- Attachment: Use (1) #10 x 1" long pancake head with #2 Philips drive or hex head per clip
- Spacing: 24" O.C. max into 15/32" plywood or 15" O.C. max into 22 gauge steel deck**
- Use 2 Clips at the eave
- Please consult BMC when applying in a coastal or high-wind load area or have special considerations.

Note:

* Not for use with aluminum.

** If specifications, local codes, or other regulations dictate specific wind uplift requirements, consult Berridge's Engineering Department at (800) 669-0009. It may be necessary to use a different clip, clip spacing, fastener, fastener spacing, or assembly.

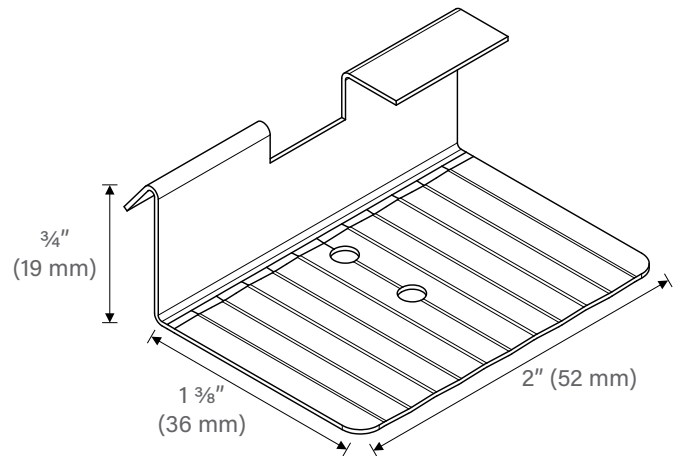

Dimensions shown above are nominal.



CORPORATE HEADQUARTERS

2610 Harry Wurzbach Road
San Antonio, TX 78209
(800) 669-0009
www.Berridge.com

All information subject to change without notice. See website for details, specifications, and Watertightness Warranty requirements.

© Berridge Manufacturing Company 2023 • (800) 669-0009 • www.Berridge.com