

PRODUCT DESCRIPTION

NO. PD 693-2

BERRIDGE PATENTED VINYL WEATHERSEAL INSERT FOR CEE-LOCK STANDING SEAM PANEL SEAM

The exclusive patented Berridge vinyl weatherseal is unique in that it is a heavy-gauge, extruded strip which exactly conforms to, and is fully covered and protected by, the 24-gauge steel integral seam and extends full length inside the female leg. Three rows of specially molded angled ribs on the inside of the vinyl weatherseal provide triple protection against siphoning of water through the seam. The effectiveness of the Berridge Patented Vinyl Insert Snap-On Seam in preventing moisture infiltration is demonstrated by the ASTM E-331-86 Water Penetration Test, conducted by an independent testing laboratory, which showed no

measurable water penetration at at 20.0 psf pressure.

The Berridge Patented Vinyl Insert Snap-On Seam is superior in performance to other types of snap-together seams (Figure 2, left) which utilize narrow strips of factory or field-applied foam tape or mastic because these other sealant methods are subject to interruption by clips or premature deterioration caused by extreme temperatures.

The patented Berridge vinyl weatherseal insert is completely and permanently protected against deterioration caused by exposure to the ultra-violet rays of the sun by the steel seam which fully encloses the full-height extruded vinyl insert.

The material used in Berridge's extruded vinyl weather seal insert is the same as that used on weatherseal moldings for modern high-rise glass curtain wall buildings and will provide decades of trouble-free performance.

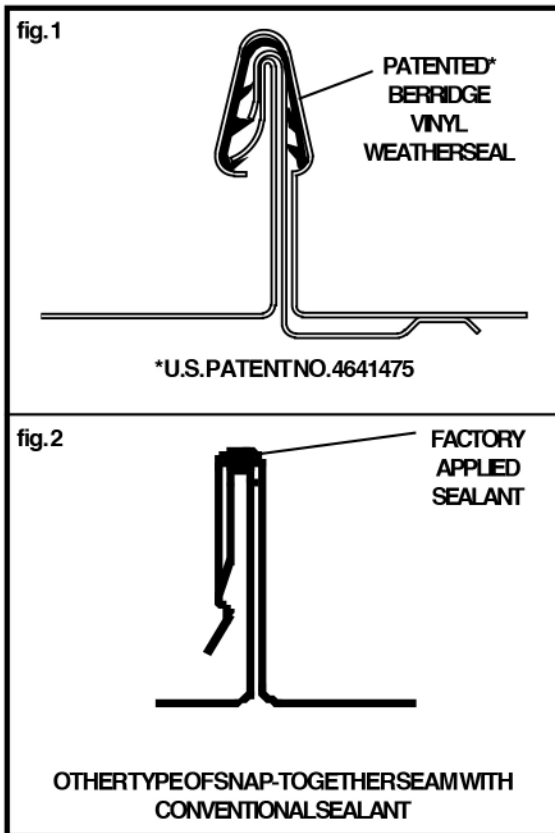

**BERRIDGE PATENTED VINYL WEATHERSEAL
INSERT FOR CEE-LOCK PANEL SEAM**
Berridge Manufacturing Company



7

Moisture & Thermal Protection:
Metal Roofing & Siding Products



BERRIDGE MANUFACTURING COMPANY

2610 Harry Wurzbach Road, San Antonio, TX 78209 | (210) 650-3050 | FAX (210) 650-0379